

"Mr. Hobby" stands for high quality hobby colors and accessories.

As a part of our company, "GSI Creos" (former "Gunze Sangyo") "Mr. Hobby" is market leader in Japan and one of the preferred brands chosen by professional model-makers around the world. Assure yourself of our quality and check out our products!



Mr. COLOR SOLVENT-BASED ACRYLIC PAINT NET : 10mL TO THIN : Mr. COLOR THINNER

Mr. COLOR is the highest quality acrylic paint in the world.
Its tone, balance, gloss and color richness are the best.
Paints for brushing and sprays are available to use as you desire.

G : GLOSS SG : SEMI-GLOSS F : FLAT M : METALLIC PA : PEARL	GLANZ HALBMATT MATT METALLISCH PERL	23 DARK GREEN DARK GREEN	P : PRIMARY GRUND C : CAR AUTO A : AIRCRAFT FLUGZEUG T : TANK&etc. PANZER S : SHIP SCHIFF II : WORLD WAR II
US : USA J : JAPAN G : GERMAN	USA JAPAN DEUTSCHLAND	UK : GREAT BRITAIN S : RUSSIA I : ISRAEL	GROß BRITANNIEN RUßLAND ISRAEL

2 : With regard to those colors marked by "2" it is recommended after the colors got dry to paint a second layer by using Mr. Super Clear Gloss (B-513) in order to achieve a deeper and more sparkling effect.

1 G WHITE WEIß P	2 G BLACK SCHWARZ P	3 G RED ROT P	4 G YELLOW GELB P	5 G BLUE BLAU P	6 G GREEN GRÜN P	7 G BROWN BRAUN P	8 M SILVER SILBER P	9 M GOLD GOLD P	10 M COPPER KUPFER P
11 SG LIGHT GULL GRAY A HELLES MÖWEN GRAU US	12 SG OLIVE DRAB (1) A OLIVGRÜN (1) US-II	13 SG NEUTRAL GRAY A NEUTRALES GRAU US-II	14 SG NAVY BLUE A MARINE BLAU US-II	15 SG JN GREEN (NAKAJIMA) A JN GRÜN (NAKAJIMA) J-II	16 SG JJA GREEN A JJA GRÜN J-II	17 SG RLM71 DARK GREEN A RLM71 DUNKEL GRÜN G-II	18 SG RLM70 BLACK GREEN A RLM70 SCHWARZ GRÜN G-II	19 SG SANDY BROWN A SAND BRAUN A G-II	20 SG LIGHT BLUE A HELLES BLAU A G-II
21 SG MIDDLE STONE A STENGRAU, MITTEL UK-II	22 SG DARK EARTH A ERDFARBE, DUNKEL UK-II	23 SG DARK GREEN (2) A DUNKEL GRÜN (2) UK-II	25 SG DARK SEAGRAY A SEEGRÄU, DUNKEL UK-II	26 SG DUCK EGG GREEN A ENTENIEIER GRÜN UK-II	27 SG INTERIOR GREEN A INNEN GRÜN US-II	28 M STEEL STAHL P	29 SG HULL RED S RUMPFROT	30 F FLAT BASE MATT GRUNDIERUNG	31 SG DARK GRAY (1) S DUNKEL GRAU (1) US-II
32 SG DARK GRAY (2) S DUNKEL GRAU (2) J-II	33 F FLAT BLACK MATT SCHWARZ P	34 G SKY BLUE P HIMMEL BLAU	35 SG JN GRAY (MITSUBISHI) A JN GRAU (MITSUBISHI) J-II	36 SG RLM74 GRAY GREEN A RLM74 GRAU GRÜN G-II	37 SG RLM75 GRAY VIOLET A RLM75 GRAU VIOLETT G-II	38 F OLIVE DRAB (2) T OLIV GRÜN (2) US	39 F DARK YELLOW (SANDY YELLOW) T DUNKEL GELB (SAND GELB) G-II	40 F GERMAN GRAY T DEUTSCHES GRAU G-II	41 F RED BROWN T ROT BRAUN G-II
42 SG MAHOGANY P MAHAGONI	43 SG WOOD BROWN P HOLZ BRAUN	44 SG TAN S GELB BRAUN	45 SG SAIL COLOR S SEGEL FARBE	46 G CLEAR P KLAR	47 G CLEAR RED P ROT, REIN	48 G CLEAR YELLOW P GELB, REIN	49 G CLEAR ORANGE P ORANGE, REIN	50 G CLEAR BLUE P BLAU, REIN	51 SG FLESH P FLEISCHFARBE
52 F FIELD GRAY (2) T FELD GRAU (2) G-II	54 F KHAKI GREEN T KHAKI GRÜN US-II	55 F KHAKI T KHAKI J-UK-II	56 SG JN GRAY GREEN (NAKAJIMA) T JN GRAU GRÜN (NAKAJIMA) J-II	57 M METALLIC BLUE GREEN A BLAUGRÜN METALLISCH J-II	58 SG ORANGE YELLOW A GELB ORANGE J-II	59 G ORANGE P ORANGE	60 SG RLM02 GRAY A RLM02 GRAU G-II	61 M BURNT IRON P-C GEBRANNTES EISEN	62 F FLAT WHITE P MATT WEIß
63 G PINK P ROSE	64 G YELLOW GREEN P-C GELB GRÜN	65 G BRIGHT BLUE P-C HELL BLAU	66 G BRIGHT GREEN P-C HELL GRÜN	67 P PURPLE P PURPUR	68 P-C MADDER RED P-C KRAPP ROT	69 P-C OFF WHITE P-C HALB WEIß	70 F DARK GREEN T DUNKEL GRÜN G-II	71 G MIDNIGHT BLUE A MITTERNACHTS BLAU US-II	72 SG INTERMEDIATE BLUE A MITTEL BLAU US-II
73 G AIRCRAFT GRAY A FLUGZEUG GRAU US	74 G AIR SUPERIORITY BLUE A LUFTWAFFEN BLAU US	75 M METALLIC RED P-C ROT METALLISCH	76 M METALLIC BLUE P-C BLAU METALLISCH	77 M METALLIC GREEN P-C GRÜN METALLISCH	78 M METAL BLACK P-C MATTAL SCHWARZ	79 G SHINE RED P LEUCHTEND ROT	80 SG COBALT BLUE P KOBALT BLAU	81 G RUSSET P ROST BRAUN	90 M SHINE SILVER P LEUCHTEND SILBER
92 SG SEMI GLOSS BLACK P SCHWARZ HALBMATT	97 G LIGHT GRAY P HELL GRAU	100 G WINE RED P WEIN ROT	101 G SMOKE GRAY P-C RAUCH GRAU	104 MG GUN CHROME P GESCHÜTZ-CHROM	107 SG CHARACTER WHITE P WEIß, FIGUR	108 SG CHARACTER RED P ROT, FIGUR	109 SG CHARACTER YELLOW P GELB, FIGUR	110 SG CHARACTER BLUE P BLAU, FIGUR	111 SG CHARACTER FLESH (1) P FLEISCHFARBE (1), FIGUR
112 SG CHARACTER FLESH (2) P FLEISCHFARBE (2), FIGUR	113 SG RLM04 YELLOW A RLM04 GELB G-II	114 SG RLM23 RED A RLM23 ROT G-II	115 SG RLM65 LIGHT BLUE A RLM65 HELL BLAU G-II	116 SG RLM66 BLACK GRAY A RLM66 SCHWARZ GRAU G-II	117 SG RLM76 LIGHT BLUE A RLM76 HELL BLAU G-II	118 SG RLM78 LIGHT BLUE A RLM78 HELL BLAU G-II	119 SG RLM79 SAND YELLOW A RLM79 SAND GELB G-II	120 SG RLM80 OLIVE GREEN A RLM80 OLIVGRÜN G-II	121 SG RLM81 BROWN VIOLET A RLM81 BRAUN VIOLETT G-II
122 SG RLM82 LIGHT GREEN A RLM82 HELL GRÜN G-II	123 SG RLM83 DARK GREEN A DUNKEL GRÜN (MITSUBISHI) G-II	124 SG DARK GREEN (MITSUBISHI) A DUNKEL GRÜN (MITSUBISHI) J-II	125 SG COWLING COLOR A-C MOTORHAUBEN FARBE J-II	126 SG COCKPIT COLOR (MITSUBISHI) A COCKPIT FARBE (MITSUBISHI) J-II	127 SG COCKPIT COLOR (NAKAJIMA) A COCKPIT FARBE (NAKAJIMA) J-II	128 SG GRAY GREEN A GRAU GRÜN J-II	129 SG DARK GREEN (NAKAJIMA) A DUNKEL GRÜN (NAKAJIMA) J-II	130 SG DARK GREEN (KAWASAKI) A DUNKEL GRÜN (KAWASAKI) J-II	131 SG RED BROWN II A ROT BRAUN II J-II
132 F EARTH GREEN T ERDGRÜN J-II	135 F RUSSIAN GREEN (1) T RUSSISCH GRÜN (1) R-II	136 F RUSSIAN GREEN (2) T RUSSISCH GRÜN (2) R-II	137 F TIRE BLACK A-C REIFEN SCHWARZ	138 G CLEAR GREEN P GRÜN, REIN	151 PA WHITE PEARL C PERL WEIß 2	156 G SUPER WHITE IV P-C SUPER WEIß IV	158 G SUPER ITALIAN RED P-C SUPER ITALIENSCH ROT	159 M SUPER SILVER C SUPER SILBER 2	171 SG FLUORESCENT RED P ROT, FLUORESZIEREND
172 SG FLUORESCENT YELLOW P GELB, FLUORESZIEREND	173 SG FLUORESCENT ORANGE P ORANGE, FLUORESZIEREND	174 SG FLUORESCENT PINK P ROSA, FLUORESZIEREND	175 SG FLUORESCENT GREEN P GRÜN, FLUORESZIEREND	181 SG SEMI-GLOSS SUPER CLEAR P HALBMATT SUPER KLAR	182 F FLAT CLEAR MATT	183 SG SUPER CLEAR GRAY TONE P SUPER KLAR GRAU TON	188 F FLAT BASE ROUGH P MATT GRUNDIERUNG RAUH	189 F FLAT BASE SMOOTH P MATT GRUNDIERUNG GLATT	
301 SG GRAY FS36081 A GRAU FS36081 US	302 SG GREEN FS34092 A GRÜN FS34092 US	303 SG GREEN FS34102 A GRÜN FS34102 US	304 SG OLIVE DRAB FS34087 A OLIVGRÜN FS34087 US	305 SG GRAY FS36118 A GRAU FS36118 US	306 SG GRAY FS36270 A GRAU FS36270 US	307 SG GRAY FS36320 A GRAU FS36320 US	308 SG GRAY FS36375 A GRAU FS36375 US	309 SG GREEN FS34079 A GRÜN FS34079 US	310 SG BROWN FS30219 A BRAUN FS30219 US
311 SG GRAY FS36622 A GRAU FS36622 US	312 SG GREEN FS34227 A GRÜN FS34227 I	313 SG YELLOW FS33531 A GELB FS33531 I	314 SG BLUE FS35622 A BLAU FS35622 I	315 G GRAY FS16440 A GRAU FS16440 US	316 G WHITE FS17875 A WEIß FS17875 US	317 F GRAY FS36231 A GRAU FS36231 US	318 SG RADOME A RADOME	319 SG LIGHT GREEN A HELL GRÜN J	320 SG DARK GREEN A DUNKEL GRÜN J

321 SG LIGHT BROWN HELL BRAUN	322 G PHTHALO CYANNE BLUE PHTHALO CYANNE BLAU	323 G LIGHT BLUE HELL BLAU	324 F LIGHT GRAY HELL GRAU	325 SG GRAY FS26440 GRAU FS26440	326 G BLUE FS15044 BLAU FS15044	327 G RED FS11136 ROT FS11136	328 G BLUE FS15050 BLAU FS15050	329 G YELLOW FS13538 GELB FS13538	330 SG DARK GREEN BS381C/641 DUNKEL GRÜN BS381C/641 UK
331 SG DARK SEAGRAY BS381C 638 SEEGRAU DUNKEL BS381C 638 UK	332 SG LIGHT AIRCRAFT GRAY BS381C 627 HELL FLUGZEUG GRAU BS381C 627 UK	333 SG EXTRA DARK SEAGRAY BS381C 640 EXTRA DUNKEL SEEGRAU BS381C 640 UK	334 SG BARLEY GRAY BS4800/1821 GERSTEN GRAU BS4800/1821 UK	335 SG MEDIUM SEAGRAY BS381C 637 MITTEL SEEGRAU BS381C 637 UK	336 SG HEMP BS4800/10B21 HANF BS4800/10B21 UK	337 SG GRAYISH BLUE FS35237 GRAUBLAU FS35237 US	338 SG LIGHT GRAY FS36495 HELL GRAU FS36495 US	339 G ENGINE GRAY FS16081 MASCHINEN GRAU FS16081 US	340 SG FIELD GREEN FS34097 FELDGRÜN FS34097 US
C351 F75% ZINC-CHROMATE TYPE I FS34151 ZINKCHROMAT TYP I FS34151	C352 F75% CHROMATE YELLOW PRIMER FS33481 CHROMATGELB GRUNDIERUNG FS33481	C361 F75% DARK GREEN BS641 DUNKELGRÜN BS641	C362 F75% OCEAN GRAY SEEGRAU	C363 F75% MEDIUM SEAGRAY BS637 MITTEL SEEGRAU BS637	C364 F75% AIRCRAFT GRAY GREEN BS283 FLUGZEUG GRAU/GRÜN BS283	C365 G GLOSS SEABLUE FS151042 GLÄNZEND SEEBLAU FS151042	C366 F75% INTERMEDIATE BLUE FS35164 MITTEL BLAU FS35164	C367 F75% BLUE GRAY FS35189 BLAUGRAU FS35189	C368 F75% SKY BS381C/210 HIMMEL BS381C/210
C369 F75% DARK EARTH BS381C/450 DUNKLE ERDE BS381C/450	C370 F75% AZURE BLUE AZURBLAU	C374 SG JASDF SHALLOW OCEAN BLUE JASDF SEICHTES SEEBLAU	C375 SG JASDF DEEP OCEAN BLUE JASDF TIEFES SEEBLAU	C376 SG JASDF RADOME GRAY JASDF RADOM GRAU	C383 SG DARK GREEN (KAWANISHI) DUNKELGRÜN (KAWANISHI)	C384 SG COCKPIT COLOR (KAWANISHI) COCKPIT FARBE (KAWANISHI)	C385 SG RED (LIN AIRCRAFT MARKING) ROT (LIN FLUGZEUGMARKIERUNG)	C391 SG INTERIOR TURKOISE GREEN (SOVIET) INNEN TÜRKIS (SOWJET)	C392 SG INTERIOR BLUE (SOVIET) INNEN BLAU (SOWJET)
C393 SG RUSSIAN AIRCRAFT BLUE II RUSSISCH FLUGZEUG BLAU II	C511 F RUSSIAN GREEN "480" RUSSISCH GRÜN "480" WWII	C512 F RUSSIAN GREEN "480" 1947-T RUSSISCH GRÜN "480" 1947-S	C513 F DARK GRAY "DUNKEL GRAU" DUNKELGRAU	C514 F GRAY "GRAU" GRAU	C515 F FADED GRAY "BLASSGRAU" BLASSGRAU	C516 F75% DARK GREEN 3414 DUNKELGRÜN 3414	C517 F75% BROWN 3606 BRAUN 3606	C518 SG OLIVE DRAB 2314 IDF GRAU 1 (-1981 Sinai)	C519 F BRONZEGRÜN BRONZEGRÜN RAL6031
C520 F LEDERBRAUN LEDERBRAUN RAL8027	C521 F TEERSCHWARZ TEERSCHWARZ RAL9021	C522 F75% GROUND COLOR GRUNDFARBE	C523 F75% GRASS COLOR GRASGRÜN	C524 F75% HAY COLOR HEUGELB	C525 F75% GREEN JAPANISCH GRÜN	C526 F75% BROWN JAPANISCH BRAUN	C527 F75% KHAKI JAPANISCH KHAKI	C528 F75% IDF GRAY1 (-1981 SINAI) IDF GRAU 1 (-1981 Sinai)	C529 F75% IDF GRAY2 (-1981 GOLAN) IDF GRAU 2 (-1981 Golan)
C530 F75% IDF GRAY3 (MODERN) IDF GRAU 3 (Modern)	C601 F LIN HULL COLOR/KURE LIN RUMPF FARBE/KURE	C602 F75% LIN HULL COLOR/SASEBO LIN RUMPF FARBE/SASEBO	C603 F75% LIN HULL COLOR/MAIZURU LIN RUMPF FARBE/MAIZURU	C604 F75% LIN TYPE21 CAMOUFLAGE COLOR LIN TYPE21 CAMOUFLAGE FARBE	C605 F75% LIN TYPE22 CAMOUFLAGE COLOR LIN TYPE22 CAMOUFLAGE FARBE	C606 F75% LIN LINOLEUM DECK COLOR LIN LINOLEUM DECK FARBE	C607 SG JMSDF 2704 GRAY N5 JMSDF 2704 GRAU N5	C608 F75% JMSDF 2705 DARK GRAY N4 JMSDF 2705 DUNKELGRAU N4	C609 F JMSDF CLEATED DECK COLOR JMSDF ANTI-RUTSCH DECK FARBE

Mr.COLOR GX

This paint features brighter color, higher foundation screening effect and stronger film than the former Mr. Color. It may be mixed with the former Mr. Color and diluted with the conventional Mr. Color Thinner or Mr. Color Leveling Thinner.

	GX 1 G COOL WHITE		GX 2 G UENO BLACK		GX 3 G HARMANN RED		GX 4 G CHIARA YELLOW
	GX 5 G SUSIE BLUE		GX 6 G MORRIE GREEN		GX 100 G SUPER CLEAR III		GX 112 G SUPER CLEAR III UV CUT GLOSS
	GX 113 F SUPER CLEAR III UV CUT FLAT		GX 114 F SUPER SMOOTH CLEAR (FLAT)				

Mr.CLEAR COLOR GX

	GX 101 G GX CLEAR BLACK		GX 102 G GX DEEP CLEAR RED		GX 103 G GX DEEP CLEAR BLUE
	GX 104 G GX CLEAR GREEN		GX 105 G GX CLEAR PINK		GX 106 G GX CLEAR ORANGE
	GX 107 G GX CLEAR PURPLE		GX 108 G GX CLEAR VIOLET		GX 109 G GX CLEAR BROWN
	GX 110 M GX CLEAR SILVER		GX 111 M GX CLEAR GOLD		

Mr.METALLIC COLOR GX

	GX 201 GX METAL BLACK		GX 202 GX METAL RED		GX 203 GX METAL YELLOW		GX 204 GX METAL BLUE		GX 205 GX METAL GREEN
	GX 206 GX METAL PURPLE		GX 207 GX METAL VIOLET		GX 208 GX ROUGH SILVER		GX 209 GX RED GOLD		GX 210 GX BLUE GOLD
	GX 211 GX METAL YELLOW GREEN		GX 212 GX METAL PEACH		GX 213 GX WHITE SILVER		GX 214 GX ICE SILVER		GX 215 GX METAL BLOODY RED
	GX 216 GX METAL DARK BLUE		GX 217 GX ROUGH GOLD						

Mr.CRYSTAL COLOR

Mr.Crystal Color can offer a totally different dimension of metallic sense from existing pearl paint or metallic paint. The pearl color shows up in different shades depending on whether the base color is black or white. Moreover, when clear paint is used for over coating, an extra special metallic texture can be achieved.

	XC 01 DIAMOND SILVER	XC 02 TOPAZ GOLD	XC 03 RUBY RED	XC 04 AMETHYST PURPLE	XC 05 SAPPHIRE BLUE	XC 06 TOURMALINE GREEN	XC 07 TURQUOISE GREEN	XC 08 MOONSTONE PEARL
Groundwork Color WHITE								
Groundwork Color BLACK								

Mr.COLOR SPECIAL SET

●10ml × 3colors

- CS631** IDF AFV COLOR SET
- CS644** WWII US NAVY WARSHIP CAMOUFLAGE COLOR SET 2
- CS645** JMSDF DESTROYER COLOR SET
- CS661** TANK COLORS FOR J.G.S.D.F.
- CS662** JAPANESE ARMY TANK COLOR EARLY VER.
- CS663** JAPANESE ARMY TANK COLOR LATE VER.
- CS664** NATO TANK COLOR
- CS665** J.A.S.D.F. OCEANIC CAMOUFLAGE COLOR SET
- CS666** J.A.S.D.F. ALUMINIZED OLD-TIMER COLOR SET

- CS667** BLUE IMPULSE COLOR SET VER.2
- CS668** KAWANISHI N1K2-J COLOR SET
- CS641** JAPANESE NAVAL ARSENAL COLOR
- CS642** JAPANESE NAVAL CAMOUFLAGE COLOR
- CS681** INTERIOR COLOR FOR AIRCRAFT (WW2)
- CS682** U.S.NAVAL AIRCRAFT (WW2)
- CS683** ROYAL AIR FORCE (WW2) EARLY
- CS684** ROYAL AIR FORCE (WW2) MIDDLE/LATE
- CS511** MECHANICAL COLOR SET Ver.RED

- CS512** MECHANICAL COLOR SET Ver.BLUE
- CS513** MECHANICAL COLOR SET Ver.YELLOW
- 18ml × 4colors
- CS551** FRESH COLOR SET FOR FIGURE
- CS561** PASTEL COLOR SET GREEN VER.
- CS562** PASTEL COLOR SET BLUE VER.
- CS563** PASTEL COLOR SET RED VER.
- CS564** Mr.COLOR SET THE GRAY
- CS643** WWII US NAVY WARSHIP CAMOUFLAGE COLOR SET 1

Mr.METAL COLOR

It provides metallic feeling when the paint surface is polished. It has a surface like metal when the dried paint surface is polished with soft cloth, though it may be painted in the same way as the former Mr. Color.
Note that the metallic feeling becomes different if clear paint is sprayed on it.

Method of use

1. When using a brush, always paint in the same direction, eg. left to right, top to bottom.
 2. After become dry, use a piece of gauze, tissue, an old cloth etc. to polish. You can create interesting effects depending on how you polish.
- Use different polishing techniques in each case, eg. no polished (for a mat effect), half-polished, very well polished.



NET:10ml

211 CHROME SILVER CHROME SILVER	212 IRON EISEN	213 STAINLESS ROSTEREISTANL	214 DARK IRON DUNKEL EISEN	215 COPPER KUPFER	216 BRONZE BRONZE	217 GOLD GOLD	218 ALUMINIUM ALUMINIUM	219 BRASS MESSING
--	-----------------------------	--	---	--------------------------------	--------------------------------	----------------------------	--------------------------------------	--------------------------------



NET:10ml

Mr.COLOR SUPER METALLIC 2	
SM 201 SUPER FINE SILVER 2	SM 202 SUPER GOLD 2
SM 203 SUPER IRON 2	SM 204 SUPER STAINLESS 2
SM 205 SUPER TITANIUM 2	SM 206 SUPER CHROME SILVER 2



NET:18ml

PRIMARY COLOR PIGMENTS

For Mr.Color

CR 1 G CYAN	CR 2 G MAGENTA	CR 3 G YELLOW
--------------------------	-----------------------------	----------------------------



Mr.COLOR SUPER METALLIC

NET:18ml

SM 03 PLATE SILVER NEXT



NET:18ml

NET:10ml

Mr.COLOR LASCIVUS

These colors were developed to be used on the skin of the figures and plastic models of characters.

01-02 NET:18ml
03-05 NET:10ml

CL01 and CL02 are for base color of skin.
CL03, CL04 and CL05 are clear pigment paint for overcoat, recommended to be used to shadow in some areas, or to express tanned skin.

CL 01 G WHITE PEACH WEISSER PFIRSICH	CL 02 G COCOA MILK SCHOKOMILCH	CL 03 G CLEAR PALE RED BLASS ROT, REIN	CL 04 G CLEAR PALE ORANGE BLASS ORANGE, REIN	CL 05 G CLEAR PALE BROWN BLASS BRAUN, REIN
--	--	--	--	--

Mr.COLOR SPRAY



NET:100ml

1 G WHITE WEIß	2 G BLACK SCHWARZ	3 G RED ROT	4 G YELLOW GELB	5 G BLUE BLAU	6 G GREEN GRÜN	8 M SILVER SILBER	9 M GOLD GOLD
11 SG LIGHT GULL GRAY HELLES MÖWEN GRAU	12 SG OLIVE DRAB (1) OLIVGRÜN (1)	13 SG NEUTRAL GRAY NEUTRALES GRAU	14 SG NAVY BLUE MARINE BLAU	15 SG JUN GREEN (NAKAJIMA) JUN GRÜN (NAKAJIMA)	16 SG IJA GREEN IJA GRÜN	28 M STEEL STAHL	29 SG HULL RED RUMPFROT
30 F FLAT CLEAR MATT KLAR	31 SG DARK GRAY (1) DUNKEL GRAU (1)	32 SG DARK GRAY (2) DUNKEL GRAU (2)	33 F FLAT BLACK MATT SCHWARZ	34 G SKY BLUE HIMMEL BLAU	35 SG JUN GRAY (MITSUBISHI) JUN GRAU (MITSUBISHI)	38 F OLIVE DRAB (2) OLIVGRÜN (2)	39 F DARK YELLOW (SANDY YELLOW) DUNKEL GELB (SAND GELB)
40 F GERMAN GRAY DEUTSCHES GRAU	41 F RED BROWN ROT BRAUN	42 SG MAHOGANY MAHAGONI	43 SG WOOD BROWN HOLZ BRAUN	44 SG TAN GELB BRAUN	46 G CLEAR KLAR	47 G CLEAR RED ROT, REIN	48 G CLEAR YELLOW GELB, REIN
49 G CLEAR ORANGE ORANGE, REIN	50 G CLEAR BLUE BLAU, REIN	58 SG ORANGE YELLOW GELB ORANGE	62 F FLAT WHITE MATT WEIß	63 G PINK ROSA	64 G YELLOW GREEN GELB GRÜN	65 G BRIGHT BLUE HELL BLAU	66 G BRIGHT GREEN HELL GRÜN
69 G OFF WHITE HALB WEIß	70 F DARK GREEN DUNKEL GRÜN	75 M METALLIC RED ROT METALLISCH	76 M METALLIC BLUE BLAU METALLISCH	77 M METALLIC GREEN GRÜN METALLISCH	78 M METAL BLACK METALL SCHWARZ	79 G SHINE RED LEUCHTEND ROT	80 SG COBALT BLUE KOBALT BLAU
92 SG SEMI GLOSS BLACK SCHWARZ HALBMATT	97 G LIGHT GRAY HELL GRAU	101 G SMOKE GRAY RAUCH GRAU	107 SG CHARACTER WHITE WEIß, FIGUR	108 SG CHARACTER RED ROT, FIGUR	109 SG CHARACTER YELLOW GELB, FIGUR	110 SG CHARACTER BLUE BLAU, FIGUR	111 SG CHARACTER FLESH (1) FLEISCHFARBE (1), FIGUR
117 SG RLM76 LIGHT BLUE HELL BLAU	124 SG DARK GREEN (MITSUBISHI) DUNKEL GRÜN (MITSUBISHI)	129 SG DARK GREEN (NAKAJIMA) DUNKEL GRÜN (NAKAJIMA)	151 PA WHITE PEARL PERLWEIß	SJ 01 C JAPANESE NAVAL ARSENAL COLOR KURE	SJ 02 C JAPANESE NAVAL ARSENAL COLOR SASEBO	81 G PURPLE PURPUR	87 G MADDER RED KRAPP ROT
89 G OFF WHITE HALB WEIß	90 M SHINE SILVER LEUCHTEND SILBER	99 M RUSSET ROST BRAUN	112 SG CHARACTER FLESH (2) FLEISCHFARBE (2), FIGUR	115 SG RLM65 LIGHT BLUE HELL BLAU	115 SG RLM65 HELL BLAU	91 M SHINE SILVER LEUCHTEND SILBER	92 SG SEMI GLOSS BLACK SCHWARZ HALBMATT

COLOR MODULATION SET

The actual figure will look three dimensional because of the shading as light falls on it, but if nothing is done after painting, the figure can give a sort of flat impression, has little presence and becomes dreary.

The technique used to emphasize the stereoscopic effect by changing the tone of even just one color is called "Color Modulation".

In some cases where you have a small piece such as a model, it is not easy to see the change just by changing the color of each surface.

So gradation painting is used to emphasize the stereoscopic effect.

CS581 18mℓ×4colors

OLIVE DRAB VER.

C 38 F OLIVE DRAB 2	CMC 01 F OD HIGHLIGHT 1
CMC 02 F OD HIGHLIGHT 2	CMC 03 F OD SHADOW

CS582 18mℓ×4colors

DARK YELLOW VER.

C 39 F75% DARK YELLOW	CMC 04 F75% DY HIGHLIGHT 1
CMC 05 F75% DY HIGHLIGHT 2	CMC 06 F75% DY SHADOW

CS583 18mℓ×4colors

GERMAN GRAY VER.

C 40 F75% GERMAN GRAY	CMC 07 F75% GG HIGHLIGHT 1
CMC 08 F75% GG HIGHLIGHT 2	CMC 09 F75% GG SHADOW

CS584 18mℓ×4colors

RUSSIAN GREEN VER.

CMC 10 SG RG CM BASE	CMC 11 SG RG HIGHLIGHT 1
CMC 12 SG RG HIGHLIGHT 2	CMC 13 SG RG SHADOW

Usage example of CS582 Dark Yellow VER.

Spray shadow (CMC06) in deeply recessed parts or around legs, and then paint overall with base color (Dark Yellow (C39)). At this time, if you repaint in such a manner as not to paint over the deep parts sprayed beforehand so that the shadow of those parts can be seen feathering through, it will give a good accent.

After giving an overall coat using base color, let's start "Color Modulation".

Use Highlight 1 (CMC04) in such a manner as to leave a reasonable amount of base color showing, and when painting try to avoid having panels painted with Highlight next to each other.

STEP 1 BASE COLOR



STEP 3 HIGHLIGHT 2



STEP 2 HIGHLIGHT 1



STEP 4 SHADOW



Add high tones using Highlight 2 (CMC05) to increase contrast.

The areas painted should be smaller than the areas painted with Highlight 1 earlier on. When sufficient contrast is obtained with Highlight 1, it is possible to use Highlight 2 to paint bolt heads, small hatches or projecting components using a brush as accents.

Lastly, try to tighten up the overall impression if it becomes blurred with white spots from Highlight painting. Use Shadow (CMC06) to paint recessed areas (deep parts) to Highlight. If Shadow is sprayed on too heavily, the contrast between bright parts and dark parts tends to be extreme, so dilute the paint to make it a little weak, then paint on little by little while observing the results and avoid fixing the color with just one coat.

The point is to clearly define "sharp" and "shaded" areas.



When painting in different colors, tools such as paper, masking tape and transparent plastic sheets can be used. When painting panel lines in different colors, mainly paper is used (with white paper it is easier to check the painting results as you go).

Hold the paper with one hand and the airbrush with the other, and hold it over the part where necessary while

spraying paint.

Move the paper away occasionally to check the results and overspray gradually to achieve a good result.



Masking tape is used for complicated shapes including round parts.

Attach masking tape firmly to prevent it lifting up.



The usages method for transparent plastic sheets (vinyl chloride sheet, etc.) is the same as that for paper. Because it is transparent, it's easier to see where it needs to go to prevent it getting out of position.



WATER BASED COLOR ACRYSION

WATER-BASED ACRYLIC PAINT NET:10mℓ TO THIN:ACRYSION THINNER

This is an epoch-making paint that can be used for both brush painting and air brush painting.

Drying speed is faster than with the existing water based hobby colors, so work efficiency is improved dramatically.

Tap water can be used to dilute the paint, but we recommend use of our dedicated thinner in order to retain 100% of the original paint performance.

N 1 G WHITE WEISS	N 2 G BLACK SCHWARZ	N 3 G RED ROT	N 4 G YELLOW GELB	N 5 G BLUE BLAU	N 6 G GREEN GRÜN	N 7 G BROWN BRAUN	N 8 M SILVER SILBER	N 9 M GOLD GOLD	N 10 M COPPER KUPFER
N 11 F FLAT WHITE MATTWEISS	N 12 F FLAT BLACK MATTSCHWARZ	N 13 F FLAT RED MATTRROT	N 14 G ORANGE ORANGE	N 15 G BRIGHT BLUE HELLBLAU	N 16 G YELLOW GREEN GELBGRÜN	N 17 SG HULL RED RUMPFROT	N 18 M STEEL STAHL	N 19 G PINK ROSA	N 20 F FLAT CLEAR KLAR MATT
N 21 G OFF WHITE GEBROCHEN WEISS	N 22 SG NEUTRAL GRAY NEUTRALES GRAU	N 23 G SHINE RED LEUCHTEND ROT	N 24 SG ORANGE YELLOW GELBORANGE	N 25 G SKY BLUE HIMMELBLAU	N 26 G BRIGHT GREEN HELLGRÜN	N 27 SG TAN GELBBRAUN	N 28 M METAL BLACK SCHWARZ METALL	N 30 G CLEAR KLAR	N 32 3/4 F GERMAN GRAY DEUTSCHES GRAU
N 33 G RUSSET ROSTBRAUN	N 34 G CREAM YELLOW CREMEGELB	N 35 G COBALT BLUE KOBALT BLAU	N 36 SG JUN GREEN (NAKAJIMA) JUN GRÜN (NAKAJIMA)	N 37 SG WOOD BROWN HOLZBRAUN	N 38 M STEEL RED STAHLROT	N 39 G PURPLE PURPUR	N 40 F FLAT BASE MATT GRUNDIERUNG	N 43 G WINE RED WEINROT	N 44 SG FLESH FLEISCHFARBEN
N 45 G LIGHT BLUE HELLBLAU	N 46 G EMERALD GREEN SMARAGDGRÜN	N 47 F RED BROWN ROTBRAUN	N 49 G VIOLET VIOLETT	N 50 G LIME GREEN LIMETTEN GRÜN	N 51 G LIGHT GULL GRAY HELLES MÖWENGRAU	N 52 SG OLIVE DRAB (1) OLIVEGRÜN (1)	N 54 SG NAVY BLUE MARINEBLAU	N 55 G MIDNIGHT BLUE MITTERNACHTS BLAU	N 56 SG INTERMEDIATE BLUE MITTELBLAU

N57 G AIRCRAFT GRAY FLUGZEUGGRAU	N58 SG INTERIOR GREEN GRÜN INNEN	N60 SG IJA GREEN IJA GRÜN	N61 G IJN GRAY (MITSUBISHI) IJN GRAU	N62 SG IJN GRAY GREEN (NAKAJIMA) IJN GRAU (NAKAJIMA)	N63 M METALLIC BLUE GREEN BLAUGRÜN METALLISCH	N66 SG RLM79 SAND YELLOW RLM79 SANDGELB	N67 SG RLM65 LIGHT BLUE RLM65 HELLEBLAU	N68 SG RLM74 GRAY GREEN RLM74 GRAUGRÜN	N69 SG RLM75 GRAY VIOLET RLM75 GRAUVIOLETT
N70 SG RLM02 GRAY RLM02 GRAU	N71 SG MIDDLE STONE STEINGRAU MITTEL	N72 SG DARK EARTH ERDFARBE DUNKEL	N73 SG DARK GREEN DUNKELGRÜN	N76 M BURNT IRON GEBRANNTES EISEN	N77 F TIRE BLACK REIFENSCHWARZ	N78 F OLIVE DRAB (2) OLIVEGRÜN (2)	N79 3/4 F DARK YELLOW DUNKELGELB	N80 F KHAKI GREEN KHAKIGRÜN	N81 F KHAKI KHAKI
N82 SG DARKGRAY (1) DUNKELGRAU (1)	N83 SG DARKGRAY (2) DUNKELGRAU (2)	N84 SG MAHOGANY MAHAGONI	N85 F SAIL COLOR SEGELFARBE	N86 G RED MADDER KRAPPROT	N87 M METALLIC RED ROT METALLISCH	N88 M METALLIC BLUE BLAU METALLISCH	N89 G METALLIC GREEN GRÜN METALLISCH	N90 G CLEAR RED ROT TRANSPARENT	N91 G CLEAR YELLOW GELB TRANSPARENT
N92 G CLEAR ORANGE ORANGE TRANSPARENT	N93 G CLEAR BLUE BLAU TRANSPARENT	N94 G CLEAR GREEN GRÜN TRANSPARENT	N95 G SMOKE GRAY RAUCHGRAU	N97 G FLUORESCENT YELLOW FLUORESZIEREND GELB	N98 G FLUORESCENT ORANGE FLUORESZIEREND ORANGE	N99 G FLUORESCENT PINK FLUORESZIEREND ROSA	N100 G FLUORESCENT GREEN FLUORESZIEREND GRÜN	N101 G FLUORESCENT RED FLUORESZIEREND ROT	N127 SG COCKPIT COLOR (NAKAJIMA) COCKPIT FARBE

ACRYSION COLOR SET
NS30 ACRYSION STARTER SET

10ml × 6colors
Measure Spoon × 3,
Mixing Stick, Brush,
Paint Tray × 2

N1 G WHITE WEIß	N2 G BLACK SCHWARZ	N3 G RED ROT	N4 G YELLOW GELB	N5 G BLUE BLAU	N6 G GREEN GRÜN
---------------------------------	------------------------------------	------------------------------	----------------------------------	--------------------------------	---------------------------------



AQUEOUS HOBBY COLOR

WATER-BASED ACRYLIC PAINT NET:10ml TO THIN:AQUEOUS HOBBY COLOR THINNER

AQUEOUS HOBBY COLOR is a water soluble, safe paint.
The paint does not dissolve once dry and the color is excellent.

H1 G WHITE WEIß	H2 G BLACK SCHWARZ	H3 G RED ROT	H4 G YELLOW GELB	H5 G BLUE BLAU	H6 G GREEN GRÜN	H7 G BROWN BRAUN	H8 M SILVER SILBER	H9 M GOLD GOLD	H10 M COPPER KUPFER
H11 F FLAT WHITE MATT WEIß	H12 F FLAT BLACK MATT SCHWARZ	H13 F FLAT RED MATT ROT	H14 G ORANGE ORANGE	H15 G BRIGHT BLUE HELL BLAU	H16 G YELLOW GREEN GELB GRÜN	H17 G COCOA BROWN KAKAOBRAUN	H18 M STEEL STAHL	H19 G PINK ROSA	H20 F FLAT CLEAR KLAR MATT
H21 G OFF WHITE HALB WEIß	H22 G GRAY GRAU	H23 G SHINE RED LEUCHTEND ROT	H24 G ORANGE YELLOW GELB ORANGE	H25 G SKY BLUE HIMMEL BLAU	H26 G BRIGHT GREEN HELL GRÜN	H27 G TAN GELB BRAUN	H28 M METAL BLACK METALL. SCHWARZ	H29 G SALMON PINK LACHSROSA	H30 G CLEAR KLAR
H31 G WHITE GREEN WEIßGRÜN	H32 G FIELD GRAY (1) FELD GRAY (1)	H33 G RUSSET ROST BRAUN	H34 G CREAM YELLOW CREME GELB	H35 G COBALT BLUE KOBALT BLAU	H36 G DARK GREEN DUNKEL GRÜN	H37 G WOOD BROWN HOLZ BRAUN	H38 M STEEL RED STAHL ROT	H39 G PURPLE PURPUR	H40 G FLAT BASE MATT GRUNDIERUNG
H41 G PALE GREEN BLAß GRÜN	H42 G BLUE GRAY BLAU GRAU	H43 G WINE RED WEIN ROT	H44 SG FLESH FLEISCHFARBE	H45 G LIGHT BLUE HELL BLAU	H46 G EMERALD GREEN SAMARAGD GRÜN	H47 G RED BROWN ROT BRAUN	H48 G FIELD GRAY (2) FELD GRAY (2)	H49 G VIOLET VIOLETT	H50 G LIME GREEN LIMETTEN GRÜN
H51 G LIGHT GULL GRAY HELLES MÖWEN GRAU	H52 SG OLIVE DRAB (1) OLIVGRÜN (1)	H53 SG NEUTRAL GRAY NEUTRALES GRAU	H54 SG NAVY BLUE MARINE BLAU	H55 SG MIDNIGHT BLUE MITTERNACHTS BLAU	H56 SG INTERMEDIATE BLUE MITTEL BLAU	H57 SG AIRCRAFT GRAY FLUGZEUG GRAU	H58 SG INTERIOR GREEN INNEN GRÜN	H59 SG IJA GREEN IJA GRÜN	H60 SG IJA GREEN IJA GRÜN
H61 G IJN GRAY IJN GRAU	H62 SG IJA GRAY IJA GRAU	H63 M METALLIC BLUE GREEN BLAUGRÜN METALLISCH	H64 SG RLM71 DARK GREEN RLM71 DUNKEL GRÜN	H65 SG RLM70 BLACK GREEN RLM70 SCHWARZ GRÜN	H66 SG RLM79 SANDY BROWN RLM79 SAND GELB	H67 SG RLM65 LIGHT BLUE RLM65 HELLE BLAU	H68 SG RLM74 DARK GRAY RLM74 DUNKEL GRAU	H69 SG RLM75 GRAY RLM75 GRAU	H70 SG RLM02 GRAY RLM02 GRAU
H71 SG MIDDLE STONE STEINGRAU, MITTEL UK-II	H72 SG DARK EARTH ERDFARBE, DUNKEL UK-II	H73 SG DARK GREEN DUNKELGRÜN UK-II	H74 SG SKY (DUCK EGG GREEN) HIMMEL (ENTENIEGER GRÜN) UK-II	H75 SG DARK SEAGRASS SEEGRAS, DUNKEL UK-II	H76 M BURNT IRON GEBRANNTES EISEN	H77 F TIRE BLACK REIFENSCHWARZ	H78 SG OLIVE DRAB (2) OLIVGRÜN (2) US	H79 SG SANDY YELLOW (DARK YELLOW) SAND GELB (DUNKEL GELB) G-II	H80 F KHAKI GREEN KHAKI GRÜN US-II
H81 F KHAKI KHAKI	H82 SG DARK GRAY (1) DUNKEL GRAU (1) US-II	H83 SG DARK GRAY (2) DUNKEL GRAU (2) J-II	H84 SG MAHOGANY MAHAGONI	H85 F SAIL COLOR SEGEL FARBE	H86 G RED MADDER KRAPP ROT	H87 M METALLIC RED ROT METALLISCH	H88 M METALLIC BLUE BLAU METALLISCH	H89 M METALLIC GREEN GRÜN METALLISCH	H90 G CLEAR RED ROT TRANSPARENT
H91 G CLEAR YELLOW GELB TRANSPARENT	H92 G CLEAR ORANGE ORANGE TRANSPARENT	H93 G CLEAR BLUE BLAU TRANSPARENT	H94 G CLEAR GREEN GRÜN TRANSPARENT	H95 G SMOKE GRAY RAUCH GRAU	H96 G SMOKE BLUE RAUCH BLAU	H301 SG GRAY FS36081 GRAU FS36081	H302 SG GREEN FS34092 GRÜN FS34092	H303 SG GREEN FS34102 GRÜN FS34102	H304 SG OLIVE DRAB FS34087 OLIVGRÜN FS34087
H305 SG GRAY FS36118 GRAU FS36118	H306 SG GRAY FS36270 GRAU FS36270	H307 SG GRAY FS36320 GRAU FS36320	H308 SG GRAY FS36375 GRAU FS36375	H309 SG GREEN FS34079 GRÜN FS34079	H310 SG BROWN FS30219 BRAUN FS30219	H311 SG GRAY FS36622 GRAU FS36622	H312 SG GREEN FS34227 GRÜN FS34227	H313 SG YELLOW FS33531 BLAU FS33531	H314 SG BLUE FS35622 BLAU FS35622
H315 G GRAY FS16440 GRAU FS16440	H316 G WHITE FS17875 WEIß FS17875	H317 F GRAY FS36231 GRAU FS36231	H318 SG RADOME RADOME	H319 SG LIGHT GREEN HELL GRÜN	H320 SG DARK GREEN DUNKEL GRÜN	H321 SG LIGHT BROWN HELL BRAUN	H322 G PHTHALO CYANINE BLUE PHTALO CYANINE BLAU	H323 G LIGHT BLUE HELL BLAU	H324 F LIGHT GRAY HELL GRAU

H325 SG GRAY FS26440 A GRAU FS26440 J	H326 G BLUE FS15044 A BLAU FS15044 US	H327 G RED FS11136 A ROT FS11136 US	H328 G BLUE FS15050 A BLAU FS15050 US	H329 G YELLOW FS13538 A GELB FS13538 US	H330 SG DARK GREEN BS381C641 A DUNKEL GRÜN BS381C641 UK	H331 SG DARK SEAGRAY BS381C638 A DUNKEL SEEGRAU BS381C638 UK	H332 SG LIGHT AIRCRAFT GRAY BS381C627 A HELL FLUGZEUG GRAU BS381C627 UK	H333 SG EXTRA DARK SEAGRAY BS381C640 A EXTRA DUNKEL SEEGRAU BS381C640 UK	H334 SG BARLEY GRAY BS480U1821 A GERSTEN GRAU BS480U1821 UK
H335 SG MEDIUM SEAGRAY BS381C637 A MITTEL SEEGRAU BS381C637 UK	H336 SG HEMP BS480U10B21 A HANF BS480U10B21 UK	H337 SG GRAYISH BLUE FS35237 A GRAUBLAU FS35237 US	H338 SG LIGHT GRAY FS36495 A HELLGRAU FS36495 US	H339 G ENGINE GRAY FS16081 A MASCHINEN GRAU FS16081 US	H340 SG FIELD GREEN FS34097 A FELDGRÜN FS34097 A	H401 F DARK GRAY T SCHWARZGRAU G-II	H402 F GREEN BROWN T GRÜNBRÄUN G-II	H403 F DARK YELLOW T DUNKEL GELB G-II	H404 F KHAKI BROWN T KHAKIBRAUN G-II
H405 F OLIVE GREEN T OLIVGRÜN G-II	H406 F CHOCOLATE BROWN T SCHOKOLADENBRAUN G-II	H413 SG RLM04 YELLOW A RLM04 GERB G-II	H414 SG RLM23 RED A RLM23 ROT G-II	H416 SG RLM66 BLACK GRAY A RLM66 SCHWARZGRAU G-II	H417 SG RLM76 LIGHT BLUE A RLM76 HELLBLAU G-II	H418 SG RLM78 LIGHT BLUE A RLM78 HELLBLAU G-II	H420 SG RLM80 OLIVE GREEN A RLM80 OLIVGRÜN G-II	H421 SG RLM81 BROWN VIOLET A RLM81 BRAUNVIOLETT G-II	H422 SG RLM82 LIGHT GREEN A RLM82 HELLGRÜN G-II
H423 SG RLM83 DARK GREEN A RLM83 DUNKELGRÜN G-II	H451 F CHALKY WHITE KALK WEIß	H452 F SOOT BLACK RUB SCHWARZ	H453 F RUST RED ROST ROT	H455 F CEMENT GRAY ZEMENT GRAU	H456 F DUST BROWN STAUB BRAUN	H457 F EARTH BROWN ERD BRAUN	H458 F MACHINE GRAY MASCHINEN GRAU	H459 F SAND YELLOW SAND GELB	H460 F RED BROWN (1) ROT BRAUN (1)
H461 F OXIDE GREEN OXID GRÜN	H462 F BLACK BROWN SCHWARZ BRAUN	H463 F RED BROWN (2) ROT BRAUN (2)	H464 F CHROME GREEN CHROMOXID GRÜN	H465 F COBALT BLUE KOBALT BLAU	H466 F PURPLE RED PURPUR ROT	H467 F CARMINE RED KARMIN ROT			

WEATHERING COLOR

NET:10ml 5colors

H341 F MUD SCHLAMM	H342 G OIL ÖL	H343 F SOOT RUB	H345 F ROUGH GRAY RAU GRAU	H346 F ROUGH SAND RAU SAND
------------------------------------	-------------------------------	---------------------------------	--	--

PREMIUM CLEAR

NET:10ml 4colors



The upgraded water based clear coating paint. The thickness of the resin and the transparency has been further developed, and the coating strength has been improved, so the surface will not be damaged with scratches easily.

- H101** AQUEOUS HOBBY COLOR PREMIUM CLEAR GLOSS
- H102** AQUEOUS HOBBY COLOR PREMIUM CLEAR SEMI GLOSS
- H103** AQUEOUS HOBBY COLOR PREMIUM CLEAR FLAT
- H104** AQUEOUS HOBBY COLOR PREMIUM CLEAR FLAT BASE

AQUEOUS HOBBY COLOR SET

HS30 AQUEOUS HOBBY COLOR SET

10ml × 8colors

H-1, H-2, H-3, H-4, H-14, H-17, H-35, H-46

Measure Spoon×3, Mixing Stick, Brush×2, Paint Tray×3, Cap Opener



THINNER FOR AQUEOUS HOBBY COLOR

This thinner contains alcohol for faster drying, though the Aqueous Hobby Color may be diluted with tap water.

It also improves adhesion to the paint surface.



T110
AQUEOUS COLOR THINNER 110
NET 110ml



T111
AQUEOUS COLOR THINNER 400
NET 400ml

THINNER FOR ACRYSION COLOR

Thinner for new water based color "ACRYSION". Dilution ratio is 3 paint : 1 thinner when you paint by airbrush.



T302
ACRYSION THINNER 110
NET 110ml



T303
ACRYSION THINNER 250
NET 250ml

T312
ACRYSION TOOL CLEANER 110
NET 110ml



T313
ACRYSION TOOL CLEANER 250
NET 250ml



T314
ACRYSION THINNER FOR AIRBRUSH 250
NET 250ml



THINNER FOR Mr.COLOR

Dilute the Mr.Color with the exclusive thinner. The standard paint-to-thinner dilution ratio is 1:1.5 to 2 for painting with an airbrush.

Use Leveling Thinner for painting with an airbrush. (It is also available for brush painting.) It improves the paint flatness and provides a glossier surface, since it contains retarder.

It even provides mat surfaces when used for mat paint.

T101
Mr.COLOR THINNER 50
NET 50ml



T102
Mr.COLOR THINNER 110
NET 110ml



T103
Mr.COLOR THINNER 250
NET 250ml



T104
Mr.COLOR THINNER 400
NET 400ml



T106
Mr.COLOR LEVELING THINNER
NET 110ml



T108
Mr.COLOR LEVELING THINNER 400
NET 400ml



T117
Mr.COLOR RAPID THINNER
NET 400ml



FINISHING MATERIALS



← COARSE
#500

#1000

#1200

FINE →
#1500



MP242
Mr. METAL PRIMER-R
NET 40ml



B504
Mr. METAL PRIMER-R
NET 100ml



Mr. Metal Primer is to be coated on metallic materials such as white metal and etching parts (brass and stainless steel) before painting. It prevents separation of paint.

B501
Mr. TOPCOAT GLOSS
NET 88ml



B502
Mr. TOPCOAT SEMI-GLOSS
NET 88ml



B503
Mr. TOPCOAT FLAT
NET 88ml



*B503 Flat may become white if it is painted thick. Spray it thinly. Do not use on humid days.

Mr. Top Coat is a coating material for surface finish. Use it for final finish of painted models. It is water-based and may be painted over both Mr. Color and Aqueous Hobby Color. It may also be painted on slide marks.

B601
Mr. PREMIUM TOPCOAT GLOSS
NET 88ml



B602
Mr. PREMIUM TOPCOAT SEMI-GLOSS
NET 88ml



B603
Mr. PREMIUM TOPCOAT FLAT
NET 88ml



These are high grade version of Mr. TOP COAT series. High quality material is used so that the whitening phenomenon that occurs due to excess spraying is minimized to the utmost. Also the thickness of the resin and the transparency has been further developed, and the coating strength has been improved, so the surface will not be damaged with scratches easily.

B513
Mr. SUPER CLEAR GLOSS
NET 170ml



B514
Mr. SUPER CLEAR FLAT
NET 170ml



B516
Mr. SUPER CLEAR SEMI-GLOSS
NET 170ml



B522
Mr. SUPER CLEAR UV CUT GLOSS
NET 170ml



B523
Mr. SUPER CLEAR UV CUT FLAT
NET 170ml



Mr. Super Clear is a finish coating material with solvent. UV Cut Clear is a special clear paint that reduces influences of UV rays. *Both are designed for Mr. Color and are not available for Aqueous Hobby Color. *B514 and B523 may become white if they are painted thick. Spray them thinly. Do not use on humid days.

R193
Mr. CLEAR COATING UV
NET 25ml



This super coating agent which exceeds even fluorine was generated using nano technology. This water-soluble solution is a safe and environmentally friendly eco product that has high performance. This is effective for protection from color fading, stains, dirt, static electricity and ultraviolet rays and for prevention of deterioration of plastic model tire parts. This can be used even on decals.

Method of use

1. Remove dirt or dust from the surface to be coated.
2. Apply coating evenly over the desired surface using tissue paper, etc. Wipe with the dry cloth that came with this product when the coated surface has dried a little (approx. 30sec. - 1min.).

R189
Mr. COMPOUND (FINE)
NET 25ml



R190
Mr. COMPOUND (SUPER FINE)
NET 25ml



R191
Mr. COMPOUND (ROUGH)
NET 25ml



This handy liquid version spreads easily and is a snap to wipe off. Uniform particle size makes Mr. COMPOUND ideal for removing scratches and smoothing down surfaces.

Method of use

1. Using a soft cloth, wipe dirt and grime from the surface you want to polish.
2. Apply a small amount of Mr. COMPOUND to the nonwoven fabric provided or to a soft cloth.
3. Without applying force, lightly and thoroughly polish the surface.

MC124
Mr. CEMENT
NET 25ml



MC127
Mr. CEMENT DELUXE
NET 40ml



MC129
Mr. CEMENT S
NET 40ml



MC131
Mr. CEMENT SP
NET 40ml



MC132
Mr. CEMENT SPB (BLACK)
NET 40ml



MC131/132: Compared with the former pour on type adhesive, drying speed has been dramatically improved and adhesive strength enhanced.

MJ194
Mr.JUST ONE-PUSH
 NET 2g



MJ197
Mr.JUST BRUSH TYPE
 NET 4g



MJ199
Mr.CLEAR GLUE
 NET 10g



MJ202
Mr.JUST SUPER FAST TYPE
 containing 3g × 2pcs



MJ203
Mr.JUST SUPER STRONG TYPE
 containing 3g × 2pcs



MN002
Mr.JUST NOZZLE FOR MJ202/203



PL01 **Mr.CEMENT LIMONENE PEN STANDARD TIP**



PL02 **Mr.CEMENT LIMONENE PEN EXTRA THIN TIP**



PL01 and PL02 are pen type cement for plastic models. It is limonene type, so it has no irritating smell of solvent and you can use it without worrying about being a nuisance to others. There is a standard type pen nib and extra thin type. Use them according to the parts you want to bond.

P118
Mr.WHITE PUTTY
 NET 30g



This may be oozed out from the tube and used as is. It is used to fill small gaps and dents. The putty will not become so hard.

P123
Mr.WHITE PUTTY R
 NET 30g



P119
Mr.DISSOLVED PUTTY
 NET 40mℓ



This is highly viscous liquid type lacquer putty. Use Surfacor 500 to finish the surface. Use Dissolved Putty to fill holes and dents.

P120 **Mr.EPOXY PUTTY HIGH DENSITY TYPE**



NET 78g

P121 **Mr.EPOXY PUTTY SUPER LIGHTWEIGHT TYPE**



NET 78g

T105
Mr.RETARDER MILD NET 40mℓ



Use this in cases where temperatures are high and Mr.Color dries too quickly, like in summer. Adding to Mr.Color by 10% or less reduces the drying speed of Mr.Color and prevents uneven and unsmooth brushing. (It may not be used for Aqueous Hobby Color.)

T113
Mr. TOOL CLEANER R 250 NET 250mℓ



This is a special liquid for only to clean tools like airbrushes and brushes. * It can not be used to dilute paint.



T116
Mr. TOOL CLEANER R 400 NET 400mℓ

T118
Mr. BRUSH CLEANER LIQUID NET 110mℓ



Special brush cleaning liquid. It will dissolve even hardened paint on a brush with its strong cleaning power. This liquid offers a rinsing effect, so the brush tip can be maintained too. After rinsing the brush with the liquid, even Mr. MASKING SOL NEO attached to a brush can be peeled off neatly. * It can not be used for airbrushes.

MJ200 **Mr.SSP PUTTY**



T114
Mr.PAINT REMOVER R NET 40mℓ



This is an exclusive paint peeler. Rub paint lightly with a brush or swab moistened with the peeler to peel off paint.

T115
REPLENISHING AGENT FOR Mr.COLOR NET 250mℓ



This product is a replenishing agent for restoring Mr.Color that has higher viscosity or is dried in a bottle. Since coating resin that is not included in Mr.Color thinner is included, the original performance of paint is restored. * This is for only Mr.Color.

MS231
Mr.MARK SOFTER NET 40mℓ



This is a softener for softening decal and sticking it to curved or irregular surfaces. Apply a small amount of mark softer on decals which is applied on parts. Wait for a minute or so and press the decal lightly with cloth or the like to stick it.

MS232
Mr.MARK SETTER NET 40mℓ



This can be used for to stick decals firmly on parts because it is including adhesive component. Using it with the mark softer :
 1) Apply the mark setter to the position where decal is to be stuck.
 2) Stick a slide mark.
 3) Spread it evenly and remove water with a swab, etc.
 4) Apply the mark softer on it, remove water again, and dry it.
 5) Pierce air bubbles with a thin needle if the decal has air bubbles. Apply the mark softer on the air bubbles and stick it.

M132
Mr.MASKING SOL NEO NET 20g



This remains elastic rubber even after drying and is suitable for masking in a wide area. Dried film cannot be cut with a design knife or the like.

M133
Mr.MASKING SOL R NET 20g



It is possible to apply it on the paint surface and cut off excess parts with a design knife or the like to make any masks as you like. Both M132 and M133 are water-soluble.

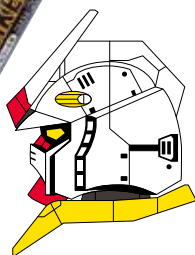

AIRBRUSH SYSTEM FOR GUNDAM MARKER

Planned by BANDAI SPIRITS CO.,LTD Hobby Products Department ©SOTSU-SUNRISE



GMA01 GUNDAM MARKER AIRBRUSH SYSTEM



- For more information on how to set up and start using, read the instruction sheet provided.
- The surface of ABS may crack if painted with this product.
- When using this product indoors, keep the room well ventilated.
- This product can be connected to Mr. Linear Compressor L5, L7, L3 and L3 Black.

GMA-01K SPECIAL REPLACEMENT NIB FOR GUNDAM MARKER AIRBRUSH SYSTEM



HOW TO GET STARTED



1 Connect the air cartridge and hose with the air valve.



2 Fill the tip of the Gundam Marker with ink by pumping it a couple of times against a painting dish.



3 Place the marker on the airbrush.



4 Carefully position the tip of the marker at the same level as the tip of the airbrush.



5 Tighten the air adjustment screw to release the air, and push the air button to let the paint come out.

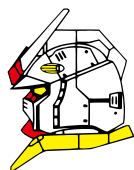

GUNDAM MARKER

Planned by BANDAI SPIRITS CO.,LTD Hobby Products Department ©SOTSU-SUNRISE



GM01 ~ GM03

GUNDAM MARKER For ink drawing (Ultra thin pen point)

3 colors (see also color sample)

Gundam marker for ink drawing is super thin for painting engraved lines, and they can give you a more mechanical looking finish. Paint run off can be erased with a rubber eraser. The marker ink fixes really well, so it is extremely easy to use. 3 colors are available, so you can use them for wide range of purposes.



- Black : For parts with dark colors like blue and gray
- Gray : Optimum for white parts
- Brown : For gold plated and red parts

GM 01 BLACK	GM 02 GRAY	GM 03 BROWN
----------------	---------------	----------------

GM04 ~ GM19

GUNDAM MARKER Paint type

17 colors (see also color sample)

GM 04 Metallic G GOLD	GM 05 Metallic G SILVER	GM 06 G BLUE	GM 07 G RED	GM 08 G YELLOW	GM 09 G EYE GREEN
GM 10 G BLACK	GM 11 G WHITE	GM 12 G GRAY	GM 13 G MECHA GRAY	GM 14 G FLUORESCENT PINK	GM 15 G FLUORESCENT GREEN
GM 16 Metallic G META RED	GM 17 Metallic G META BLUE	GM 18 Metallic G META GREEN	GM 19 Metallic G META VIOLET	GM 300 ERASURE	

Gundam marker for painting is a popular marker with which you can reproduce the original colors of Gundam and BB Warriors easily. The pen point is a "flat core" that is most suitable for detailed painting, and a good color and smooth coverage alcohol type paint is used. 6 metallic colors, 3 fluorescent colors, 7 special colors and an eraser pen, a total of 17 varieties are available.

GM300 ERASURE MARKER



This is a removing liquid of pen type which removes GUNDAM MARKER painted onto the parts. You can dare to paint the small parts carelessly and then remove the excess paint.

GM20 · GM21

GUNDAM MARKER for ink drawing (Wipe off type)

2 colors (see also color sample)

Gundam marker ink drawing brush pen is the ultimate marker for ink drawing the finer engraved lines. It has a brush type pen point, so you can paint any detailed engraved parts. Furthermore, special water-based ink is used, so you can over paint it on Mr.Color, Aqueous Hobby Color and ACRYSION and any paint run off can be wiped off with a cotton bud, etc. This pen has the power to increase the reality of any kind of model.



GM 20 BLACK	GM 21 GRAY
----------------	---------------

GUNDAM MARKER SET

GMS105 GUNDAM MARKER BASIC SET

A 6 color set with 1 color brush pen for ink drawing and 5 colors of Gundam marker, which contains quick drying alcohol type paint and provides an outstanding strength paint film.



GM 06 G BLUE	GM 07 G RED	GM 08 G YELLOW
GM 11 G WHITE	GM 21 Wipe off (GRAY)	GM 22 G METALLIC

GMS108 GUNDAM MARKER ZEON SET

All colors for Char's Zaku and Zaku. Moreover, we have developed special paint for this set, so you can get a smooth painted surface with very little irregularity of color.



GM 34 CHAR PINK	GM 35 CHAR RED	GM 36 ZAKU DARK GREEN
GM 37 ZAKU LIGHT GREEN	GM 38 PHANTOM GRAY	GM 39 ZEON GRAY

GMS109 GUNDAM MARKER GUNDAM SEED BASIC SET

A set of markers for the popular Gundam Seed. All the basic colors for Strike and Freedom come as a set.



GM 40 SEED RED	GM 41 SEED YELLOW	GM 42 SEED WHITE
GM 43 SEED BLUE	GM 44 SEED GRAY	GM 45 SEED DARK BLUE

GMS110 GUNDAM MARKER THIN POINT TYPE SET

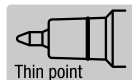

A set of thin pen point type markers that are especially effective for painting fine parts such as the face, vernier and eyes of Gundam.



GM 46 G RED	GM 47 G YELLOW	GM 48 G BLACK
GM 49 G WHITE	GM 50 G FLUORESCENT PINK	GM 51 G META GREEN

GMS112 REAL TOUCH MARKER SET 1

Convenient set for realistic weathering and smudging painting effects. If you use this set with Real Touch Marker set 2, you'll broaden your range of painting. This is a set of water-based wipe off type markers.



GM 401 REAL TOUCH GRAY 1	GM 402 REAL TOUCH GRAY 2	GM 403 REAL TOUCH BLUE 1
GM 404 REAL TOUCH RED 1	GM 405 REAL TOUCH ORANGE 1	GM 400 GRADING MARKER

GMS113 REAL TOUCH MARKER SET 2

Convenient set for realistic weathering and smudging painting effects. If you use this set with Real Touch Marker set 1, you'll broaden your range of painting. This is a set of water-based wipe off type markers.



GM 406 REAL TOUCH GRAY 3	GM 407 REAL TOUCH BROWN 1	GM 408 REAL TOUCH GREEN 1
GM 409 REAL TOUCH YELLOW 1	GM 410 REAL TOUCH PINK 1	GM 400 GRADING MARKER

GMS114 GUNDAM MARKER GUNDAM SEED DESTINY MARKER SET

A set of colors for "Impulse Gundam", the main figure of Gundam Seed Destiny. Light blue and yellow markers have thin pen point and are easy to use.



GM 58 SEED DESTINY WHITE	GM 59 SEED DESTINY RED	GM 60 SEED DESTINY BLUE
GM 61 SEED DESTINY LIGHT BLUE	GM 62 SEED DESTINY YELLOW	GM 63 Wipe off (BLACK)

GMS121 GUNDAM METALLIC MARKER SET

A set of markers which provides metallic feelings on the parts easily. 5 metallic colors and a MARKER for ink drawing are included.



GM 151 G METALLIC GOLD	GM 152 G METALLIC SILVER	GM 153 G METALLIC BLUE
GM 154 G METALLIC GREEN	GM 155 G METALLIC RED	GM 20 Wipe off (BLACK)

GMS122 GUNDAM MARKER POUR TYPE SET

A set of markers including new colors for the popular pour type marker which can pour ink into the mold easily. 5 colors and ERASURE MARKER are included, and you can use it as your usage.



GM 300 ERASURE	GM 302 GRAY	GM 303 BROWN
GM 311 BLUE 1	GM 312 ORANGE 1	GM 313 OLIVE

One-point advice on GUNDAM MARKER

When you need to paint small parts or places where the pen point cannot reach, put ink in a paint dish and paint it with a thin brush.



GUNDAM MARKER SET

GM124 GUNDAM MARKER ADVANCED SET



This is a new marker set for latest GUNPLA. We investigated and pursued latest and accurate color of GUNDAM, also each markers can be used for various GUNPLA because these are almost basic colors such as white, blue and red.

GM 166 NEW WHITE	GM 167 RED GOLD	GM 168 LIGHT BLUE
GM 169 PURPLE	GM 170 TITAN'S BLUE	GM 171 CHAR PINK 2

GP01 GUNDAM INK DRAWING PEN "SHARP"



Recommended by GUNPLA master-hand, Kawaguchi. Super easy ink drawing in the recessed line moldings on GUNPLA. You can draw in the recessed mold lines smoothly with ink using the ultra thin pen point of 0.3mm. You can get a sharp and realistic look easily even without painting. Paint run off can easily be removed with a rubber eraser. This is a mechanical pencil type ink drawing pen.



GP02 EXTRA LEAD FOR "SHARP" (10PCS)

©SOTSU·SUNRISE

GM301 ~ GM303 GUNDAM MARKER POUR TYPE BLACK

3 colors (see also color sample)



You can pour ink into the mold only by putting the tip of the pen. You can use a rubber eraser for the excess paint.

GM 301 BLACK	GM 302 GRAY	GM 303 BROWN
------------------------	-----------------------	------------------------

GUNDAM MARKER LINER "SHARP" TYPE / BRUSH TYPE

Mark the mold lines for a sharper and more three dimensional appearance. Choose the right color of the marker according to the color of the plastic parts. Use the black marker for dark colored parts, gray marker for light colored parts and brown marker for reddish colored parts. You can easily ink in your Gunpla for more realistic appearance by using the pour type Gundam Marker.



The Liner type marker can be used to ink in your Gunpla by drawing over the engraved lines.



The Brush type can be applied by letting the ink run down the engraved lines, or coloring the entire surface of plastic parts and wipe off after.



The excess ink can be removed with an eraser if the plastic parts are unpainted.



Put the tip of the marker against the engraved line, and press the pen gently to allow the ink to come out and run down along the line.



The excess ink can be easily removed with an eraser.



The excess ink can be easily removed with an eraser.

GUNDAM COLOR



Planned by
BANDAI SPIRITS CO.,LTD Hobby Products Department
©SOTSU·SUNRISE



UG01 ~ UG17 GUNDAM COLOR SINGLE ITEMS

17 colors (see also color sample) NET:10mℓ

UG 01 Semi gross MS WHITE	UG 02 Semi gross MS BLUE	UG 03 Semi gross MS YELLOW	UG 04 Semi gross MS RED	UG 05 Metallic U.N.T.'s MS GRAY
UG 06 Semi gross MS GREEN	UG 07 Semi gross MS DEEP GREEN	UG 08 Semi gross MS PURPLE	UG 09 Semi gross ZEON'S MS GRAY	UG 10 Semi gross MS CHAR'S PINK
UG 11 Semi gross MS CHAR'S RED	UG 12 Semi gross MS SAZABI RED	UG 13 Semi gross A.E.U.G.'s MS BLUE	UG 14 Semi gross MS LIGHT BLUE	UG 15 Semi gross MS PHANTOM GRAY
UG 16 Semi gross MS TITANS BLUE 1	UG 17 Semi gross MS TITANS BLUE 2			



UG18 ~ UG21 GUNDAM COLOR FOR BUILDERS

4 colors (see also color sample) NET:10mℓ

UG 18 Semi gross RX-78 WHITE Ver. ANIME COLOR	UG 19 Semi gross RX-78 BLUE Ver. ANIME COLOR	UG 20 Semi gross RX-78 RED Ver. ANIME COLOR	UG 21 Semi gross RX-78 YELLOW Ver. ANIME COLOR	
---	--	---	--	--

GUNDAM COLOR SPRAY

GUNDAM COLOR SPRAY

Planned by
BANDAI SPIRITS CO.,LTD Hobby Products Department
©SOTSU-SUNRISE



SG01 ~ SG15
GUNDAM COLOR SPRAY

15 colors (see also color sample) NET:100ml

SG 01 Semi gloss MS WHITE	SG 02 Semi gloss MS BLUE	SG 03 Semi gloss MS YELLOW	SG 04 Semi gloss MS RED	SG 05 Metallic U.N.T.'s MS GRAY
SG 06 Semi gloss MS GREEN	SG 07 Semi gloss MS DEEP GREEN	SG 08 Semi gloss MS PURPLE	SG 09 Semi gloss ZEON'S MS GRAY	SG 10 Semi gloss MS CHAR'S PINK
SG 11 Semi gloss MS CHAR'S RED	SG 12 Semi gloss MS SAZABI RED	SG 13 Semi gloss A.E.U.G.'s MS BLUE	SG 14 Semi gloss MS LIGHT BLUE	SG 15 Semi gloss MS PHANTOM GRAY

Spray type Gundam COLOR. These are based on Mr. Color, so of course it is easy to use and provides excellent color and finish.

Please use together with Gundam COLOR sets and Gundam MARKER.

GUNDAM MARKER REAL TOUCH MARKER

GM400 ~ GM410 11 colors (see also color sample)



Available in thin and broad pen tip.

Individual Real Touch Markers. These markers have been really popular since they were first launched.

With this marker, you can give the effect of stains and smudging easily with a realistic touch. Water-based paint is used for safety.

GM 400 Grading Marker	GM 401 REAL TOUCH GRAY 1	GM 402 REAL TOUCH GRAY 2	GM 403 REAL TOUCH BLUE 1	GM 404 REAL TOUCH RED 1
GM 405 REAL TOUCH ORANGE 1	GM 406 REAL TOUCH GRAY 3	GM 407 REAL TOUCH BROWN 1	GM 408 REAL TOUCH GREEN 1	GM 409 REAL TOUCH YELLOW 1
GM 410 REAL TOUCH PINK 1				

Before use



After use



Step 1

Paint all over with Mr. Super Clear Flat or Top Coat Flat.



B514
Mr.SUPER
CLEAR
FLAT
NET 170ml

B503
Mr.TOPCOAT
FLAT
NET 88ml



Step 2

Paint the edges of the parts lightly with a Real Touch Marker.



Step 3

GM400 Blend ink with a Real Touch Smudging Marker.



Step 4

Wipe off excess ink by rubbing with a cotton bud or tissue paper.



Mr.WEATHERING COLOR

NET 40mℓ

Special paint for weathering presentation based on oil paint material. It can be used on its own, but brightness can be adjusted by mixing it with other colors. It is possible to apply this over the base color of Mr. Color, Aqueous hobby color and Acrylic color.

WC01

WEATHERING COLOR
MULTI BLACK



WC02

WEATHERING COLOR
GROUND BROWN



WC03

WEATHERING COLOR
STAIN BROWN



WC04

WEATHERING COLOR
SANDY WASH



WC05

WEATHERING COLOR
MULTI WHITE



WC06

WEATHERING COLOR
MULTI GRAY



WC07

WEATHERING COLOR
GRAYISH BROWN



WC08

WEATHERING COLOR
RUST ORANGE



Mr.WEATHERING COLOR FILTER LIQUID

NET 40mℓ

When this is applied broadly using a flat brush, etc. on a surface painted with basic color and then wiped off lightly with cotton buds, etc., the color tone on the painted surface can be matched and shading or shadowing can be added to enhance 3D appearance.

*Filtering: Painting method to replicate fading of coating.

WCT101

WEATHERING COLOR
THINNER 110mℓ

Dedicated thinner for Weathering color. Use it for wiping Weathering color, adjusting the viscosity or cleaning. You can use it without damaging the base color painted on using Mr. Color, Aqueous hobby color or Acrylic color.



WC09

FILTER LIQUID
SHADE BLUE



WC10

FILTER LIQUID
SPOT YELLOW



WC11

FILTER LIQUID
LAYER VIOLET



WC12

FILTER LIQUID
FACE GREEN



Mr.WEATHERING LINER

PP201

Mr.WEATHERING LINER
RUST COLOR SET

PL01
RUST RED

PL02
RUST ORANGE

PL03
SOOT BLACK



PP202

Mr.WEATHERING LINER
MUD COLOR SET

PL04
SAND BROWN

PL05
MUD BROWN

PL06
DEEP BROWN



PP203

Mr.WEATHERING LINER
SNOW COLOR SET

PL07
WHITE

PL08
LIGHT GRAY

PL09
GRAY



WCT102

WEATHERING COLOR
THINNER 250mℓ



WEATHERING PASTEL SET

This is a pastel set suitable for expressing dirtiness, dust and mud. It is powdery and may be used as is.



PP101

WEATHERING PASTEL SET 1

NET 15g × 3colors

PW01
DARK BROWN

PW02
LIGHT BROWN

PW03
SAND



PP102

WEATHERING PASTEL SET 2

NET 15g × 3colors

PW04
CHARCOAL GRAY

PW05
LIGHT GRAY

PW06
RUST ORANGE



Dusty expression: Take it with a brush and place it as is.



Muddy expression: Dissolve it with Aqueous Color Thinner and rub solution with a brush or swab.

Mr.WEATHERING PASTE

NET 40mℓ

It is most suitable for reproducing three dimensional stains such as mud. When used on its own, you can create a puddle effect. WP03 WET CLEAR can reproduce a moistened texture when it is mixed with other WEATHERING PASTE. *It can not be used by airbrushes.



WP01 WEATHERING PASTE
MUD BROWN



WP02 WEATHERING PASTE
MUD WHITE



WP03 WEATHERING PASTE
WET CLEAR



DIORAMA SAMPLE



WP04 WEATHERING PASTE
MUD YELLOW



WP05 WEATHERING PASTE
MUD RED



Mr. BRUSH

This is a painting brush with a silicone grip developed first in the world. It uses very durable PBT (chemical fiber) bristles to solve such problems as cut-off and fall-out of the bristles.

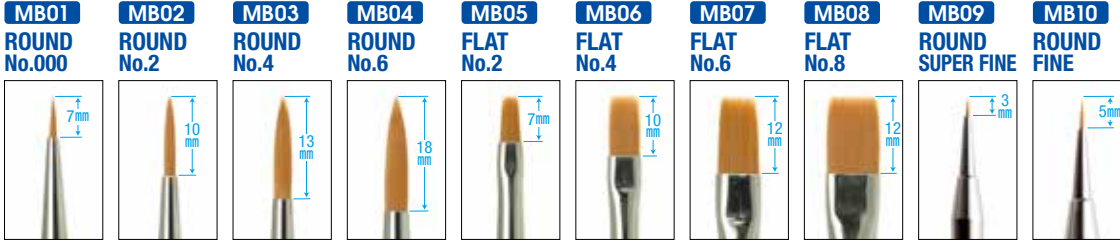

Mr. WEATHERING BRUSH & SPONGE

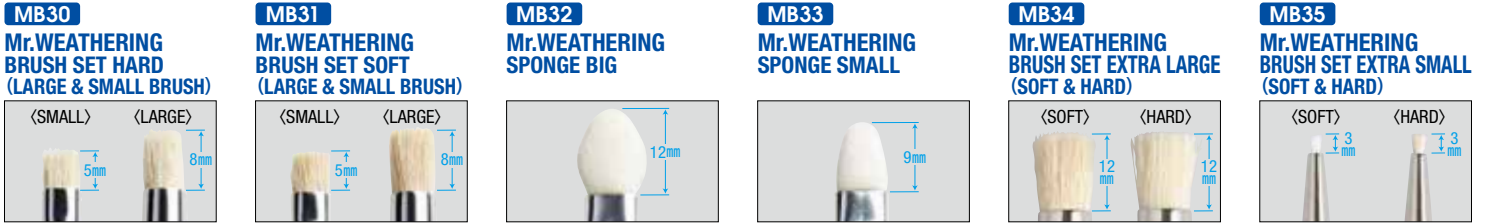

FT03 Mr.SUPER BOOTH COMPACT



FT-03H HONEYCOMB FILTER FOR Mr.SUPER BOOTH COMPACT



FT-03S HOOD SET FOR Mr.SUPER BOOTH COMPACT

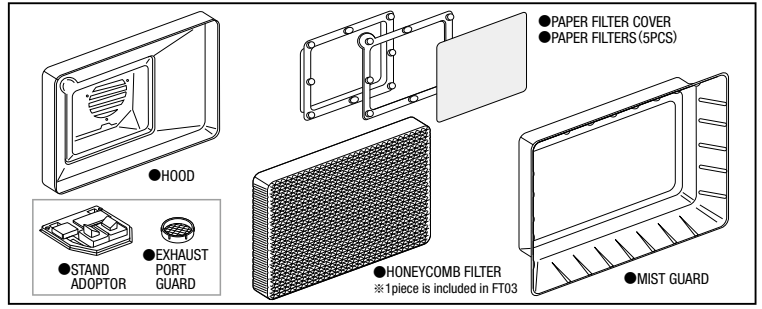

GT-03H HONEYCOMB FILTER



GT-03F INNER FILTER



GT-03C PAPER FILTER COVER



GT-03E VENT ATTACHMENT



GT-03D EXTENSION DUCT HOSE

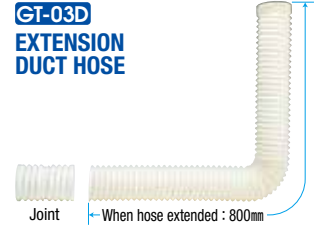

GT68 Mr.PAINT STAND
● 4PCS IN PACKAGE

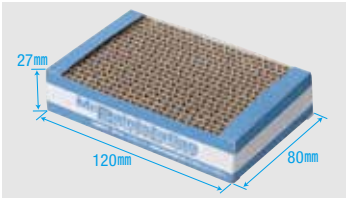

GT89 Mr.ALMIGHTY CLIP BASE

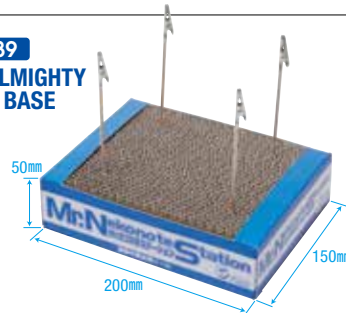

GT110 Mr.ALMIGHTY CLIP BASE LARGE

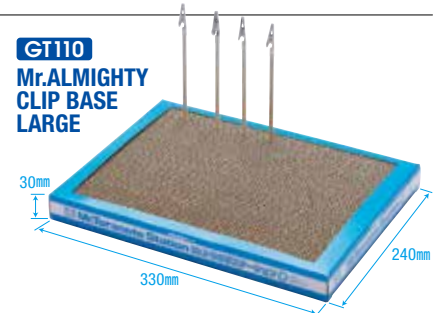

GT34 Mr.ALMIGHTY CLIP II



GT88 Mr.ALMIGHTY CLIP III (clip w/stand)



GT46 ASSIST PARTS (A) FOR GT34



GT52 ASSIST PARTS (B) FOR GT34



GT-46P PARTS FIXING RUBBER FOR GT34



GT90 Mr.ALMIGHTY CLIP STICK (one end 36pcs)



GT100 Mr.ALMIGHTY CLIP STICK (both ends 24pcs)



GT101 Mr.ALMIGHTY CLIP STICK MINI



GT102 Mr.ALMIGHTY CLIP STICK DELUXE

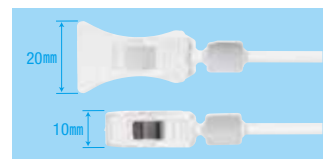

GT104 Mr.ALMIGHTY CLIP 20mm WIDTH TYPE



GT109 Mr.PAINT STIRRING ROD



GT111 Mr.ALMIGHTY CLIP WIDE 34pcs



GT01 Mr.CORDLESS ROUTER

● TWO AAA ALKALINE DRY BATTERY USE (OPTIONAL)



GT09 Mr.CORDLESS ROUTER PROII

● TWO AAA ALKALINE DRY BATTERY USE (OPTIONAL)



GT-01A BASIC SANDER SET



GT-01B POWERFUL SANDER SET



GT-01C PRECISE SANDER SET



GT-01D DIAMOND SANDER SET



GT-01E SMALL SANDER SET



GT-01F STIRRER ATTACHMENT



GT10 Mr.ROUTER PROIII AC ADAPTOR TYPE



A router using the household power supply. A certain level of voltage is applied, so work efficiency is increased. A commercial bit with a shaft diameter of 2.35mm can be set in addition to the supplied bits.

Accessories : 7 tip bits

GT08 Mr.CORDLESS POLISHERII

● TWO AAA ALKALINE DRY BATTERY USE (OPTIONAL)



GT-08A GRINDING CLOTH SHEET (ROUGH)



GT-08C WATERPROOF SANDPAPER SET (ROUGH)



GT-08D WATERPROOF SANDPAPER SET (FINE)



GT-08E REPLACEMENT HEAD PARTS



GT07 Mr.POLISHER PRO

● TWO AA ALKALINE DRY BATTERY USE (OPTIONAL)



EXCHANGE WATERPROOF SANDPAPER

- GT38 #600
- GT39 #800
- GT40 #1000
- GT48 #400
- GT95 #220



GT41 REPLACEMENT HEAD PARTS



DC901 Mr.STORAGE BOX



GT73 Mr.METAL BALL



GT56 Mr.CAP OPENER



GT94 Mr.STAND



GT84 Mr.ROUND CASE



MB20 Mr.CLEANING-ANTI STATIC BRUSH (BLACK GOAT HAIR)



155mm

150mm

MB21 Mr.CLEANING-ANTI STATIC BRUSH MINI

GT53 FINELY SLIT MASKING SHEET SET

● W : 1mm × L : 166mm × 90SHEETS
● W : 2mm × L : 166mm × 45SHEETS

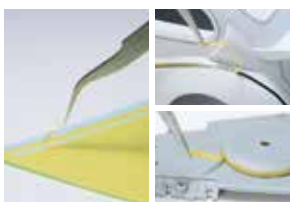

GT71 MASKING SHEET SET ROUND & TRIANGLE

● φ3mm・φ5mm ROUND MASKING SHEET × 1
3mm TRIANGLE MASKING SHEET × 1

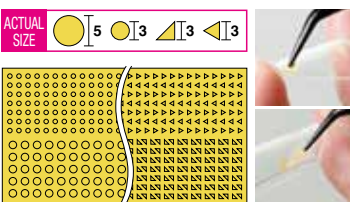

GT107 Mr.FOLDABLE SILICONE BOX WITH SLIP-PROOF BOTTOM



175mm

125mm

50mm
20mm

GT78 Mr.T-TYPE RULER



Usage example

GT82 Mr.T-TYPE RULER LARGE



Mr. T-type ruler is a tool for drawing right angle lines. You can hook the shorter scale side on the edge of the object, and you can check right angles or draw a line.

GT91 Mr.UN-SLIP SHEET

● SIZE 300mm × 300mm

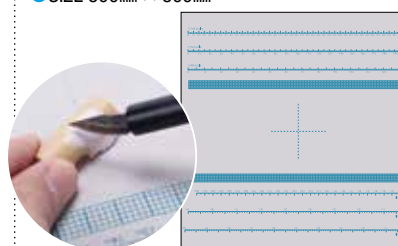

GT57 Mr. GLUE APPLICATOR

This is a convenient tool for spot application of quick-drying glue, putty filling and putty building up. Quick-drying glue adhered to itself may be removed easily.



GT58 Mr. GRINDING CLOTH SET (ROUGH 400-600-800)
● SIZE : 93mm×210mm



This polishing cloth is made of polyester mesh and abrasive agent. It is durable and may be washed with water and reused. It is very economical. The products with larger numbers have finer meshes.

GT36 Mr. GRINDING CLOTH SET (FINE 1000-2000-3000)
● SIZE : 93mm×210mm



GT61 Mr. WATER PROOF POLISHING CLOTH #2400 #4000
● SIZE : 93mm×230mm



GT62 Mr. WATER PROOF POLISHING CLOTH #6000 #8000
● SIZE : 93mm×230mm



GT80 Mr. ANTI-STATIC CLOTH
● SIZE : 200mm×400mm

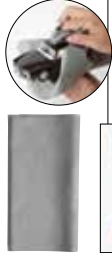

GT81 Mr. PHOTOETCHED PARTS BENDER

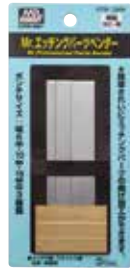

GT31 Mr. FINISHING CLOTH (SUPER FINE)
● SIZE : 300mm×300mm



GT31 is used for final finish of compound polishing. GT32 is used for coarse compound polishing and water removal after washing.

GT32 Mr. FINISHING CLOTH (FINE)
● SIZE : 300mm×700mm



GT105 MR. MELAMINE FOAM SHEET FOR FLAT FINISH



GT106 MR. MELAMINE FOAM STICK FOR FLAT FINISH



GT50 Mr. PINVICE BASIC SET (DRILL BLADE FIXATION TYPE)
● WITH IN THE CASE STORAGE

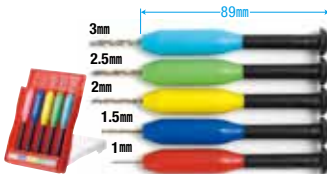

GT92 Mr. HULL MOLD CHISEL



GT65 Mr. LINE CHISEL (0.3 BLADE IS INCLUDED)
◆ Blade is detachable

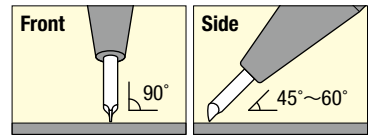

GT-65RA Mr. LINE CHISEL RED ANODIZED ALUMINUM (0.3 BLADE IS INCLUDED)
◆ Blade is detachable

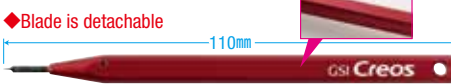

The cutting edge is attached to the other side of the flat surface of grip. Put the blade against the part to be carved at a right angle and to pull your side to carve. Adjust the depth of groove to be carved by controlling the force put to the blade. Viewing from the side, the adequate angle between the surface of part and the grip is 45 to 60 degrees.

GT70 Mr. RIVET MARKING

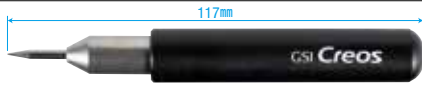

◁ Items included in the set ▷

- Main body,
- 0.25mm tip tool (length 29mm)
- 0.45mm tip tool (length 30mm)
- 0.60mm tip tool (length 31mm)
- L shaped wrench

Mr. Rivet Marking is a tool for reproducing the appearance of rivets in aircraft and tank models. The tip part rotates when the main body is pushed down, so without pressing it hard you can make sharp and even ○ shaped rivet heads. 3 kinds of tip tool are furnished and they can be easily interchanged with a wrench. Various scale kits can be handled with this tool alone.

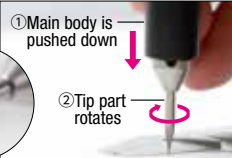

GT-65A 0.3mm BLADE FOR GT65



GT-65B 0.2mm BLADE FOR GT65



GT-65C 0.15mm BLADE FOR GT65



GT-65D 0.1mm BLADE FOR GT65



GT-65E 0.5mm BLADE FOR GT65



GT-65F NEEDLE BLADE FOR GT65



GT-65G 0.7mm BLADE FOR GT65



GT-65H 1.0mm BLADE FOR GT65



GT-65I 1.2mm BLADE FOR GT65



GT108 Mr. MODELING SAW



This is a blade-replaceable saw for plastic modelling. It has a movable blade guard inside the grip. If a blade becomes blunt, it can be replaced with blades which are sold separately.

GT-108A Mr. MODELING SAW REGULAR BLADE



GT-108B Mr. MODELING SAW BLADE FOR RESIN PARTS



GT-108C Mr. MODELING SAW 0.1mm BLADE FOR PLASTIC PARTS

GT97 Mr. EASY NIPPER



GT66 Mr. VICE

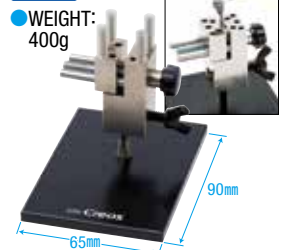

MK01 Mr. CARVING KNIFE HG



GT114 Mr. SCRAPER 1

This compact scraper can be used in small area and gaps where sand papers would be hard to reach. It can scrape off parting lines and markings of extrusion pin. To use this tool, simply scrape off by pulling towards you. It can scrape off easily and efficiently with no fuss.

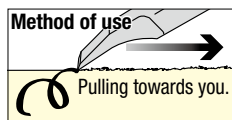

MF08 Mr. CHIPPING RUBBER



LP01 Mr. MAGNIFIER LAMP



LP02 Mr. GLASS LOUPE



GT75 Mr.PRECISION CARVING KNIFE (FLAT BLADE IS INCLUDED)

◆Blade is detachable



GT-75A FLAT BLADE FOR GT-75



GT87 Mr.CARVING KNIFE (ANGULAR BLADE IS INCLUDED)

◆Blade is detachable



GT-75B THIN FLAT BLADE FOR GT-75



GT-75C INCLINED BLADE FOR GT-75



GT-75D V-SHAPED BLADE FOR GT-75



GT-75E ROUND BLADE FOR GT-75



GT-75F SCRAPER FOR GT-75



GT-75G TRIANGLE BLADE FOR GT-75



GT-87A ANGULAR BLADE FOR GT87 Mr.CARVING KNIFE



GT-87B ROUND BLADE FOR GT87 Mr.CARVING KNIFE



GT-87C SINGLE EDGED ANGULAR BLADE FOR GT87 Mr.CARVING KNIFE



GT63 Mr.RASPS



MF02 FILE ROUND TYPE (φ3.2)



MF05 FILE BLADE TYPE



MF06 FILE TAPERED TYPE (1 SIDE BLADE)



MF07 FILE FLAT TYPE (4 SIDE BLADE 0.5 THICKNESS)



MF09 Mr.DIAMOND FILE #600



MF10 Mr.DIAMOND FILE #1000 W / HOLDER



MF11 REPLACEMENT TYPE DIAMOND FILE

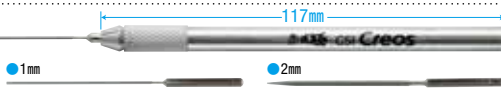

MF12 KIWAMI MODELING FILE DEAD SMOOTH CUT



MF13 KIWAMI MODELING FILE SINGLE CUT FLAT (SMOOTH)



MF14 KIWAMI MODELING FILE SINGLE CUT FLAT (COARSE)



MF15 KIWAMI MODELING FILE SINGLE CUT - HALF ROUND



MF16 KIWAMI MODELING FILE SINGLE CUT - SQUARE



MF18 KIWAMI - GINREI - RIFFLER DIAMOND FILE #400



MF17 KIWAMI UNYO TWO SIDED SINGLE CUT PLATE FILE



GT93 Mr.TWEEZERS PARTS HOLDER



GT103 Mr.TWEEZERS PARTS HOLDER with LOCK MECHANISM



Mr.TOOLS

MT102 Mr.Nipper



MT103 Mr.Nipper GX (Single-Edged)



MT104 Mr.Basic Nipper II



MT201 Mr.BASIC TWEEZERS



MT202 Mr.PRECISION TWEEZERS



MT203 Mr.ANGLED TWEEZERS



MT204 Mr.BEVEL TWEEZERS



MT301 Mr.WATERPROOF SAND PAPER SET ROUGH #400×2, #600×2, #1000×2



MT302 Mr.WATERPROOF SAND PAPER SET FINE #1200×2, #1500×2, #2000×2



MT303 Mr.WATERPROOF SAND PAPER #180 #180×4



MT304 Mr.WATERPROOF SAND PAPER #400 #400×4



MT305 Mr.WATERPROOF SAND PAPER #600 #600×4



MT306 Mr.WATERPROOF SAND PAPER #800 #800×4



MT307 Mr.WATERPROOF SAND PAPER #1000 #1000×4



MT308 Mr.WATERPROOF SAND PAPER #1500 #1500×4



MT309 Mr.WATERPROOF SAND PAPER #2000 #2000×4



MT401
Mr.PAPER
CARDTYPE
SAND PAPER
#240



MT402
Mr.PAPER
CARDTYPE
SAND PAPER
#400



MT403
Mr.PAPER
CARDTYPE
SAND PAPER
#600



MT404
Mr.PAPER
CARDTYPE
SAND PAPER
#800



MT405
Mr.PAPER
CARDTYPE
SAND PAPER
#1000



DS001 Mr.TURN TABLE L



- Rotation speed : 2 step switching (2.0/1.0 rotations per min.)
- Power supply : AA dry cell batteries × 3 (available separately)
- Capable of load : up to 2kg

Mr. Turn Table can be used for large sized models, with its diameter of 189mm. Using a switch you can select between 2 rotation speeds (low/high). The table part has a mirror finish offering a touch of class.



VANCE MATERIAL

VANCE ACCESSORIES LED MODULE

VANCE ACCESSORIES LED MODULES are easy-to-setup LED lights; simply joint the sockets together. You can create an illuminating plastic model with no fuss; there is no need to calculate electric power and solder the cables.

VAL-01 1608 CHIP LED



1608 CHIP LED can be placed on different parts of your plastic model as it is small, so it can be easily installed even if it is your first time installing LED lighting. Although the lightbulb is small, it gives a high light luminance.



1608 CHIP LED lightbulb has been soldered onto the end of the cable.



VAL-02 3mm SHELL TYPE LED



An artillery shell shaped LED with outer diameter of 3mm has been modularized to make VAL-02 series. It can be easily installed by simply drilling with 3mm wide pin vice where you want to put the LED. As it is more suitable to be installed on the exterior of the plastic model than the CHIP LED, we have chosen the bulb color to be clear, so that it would not spoil the overall appearance.

Artillery shell shaped 3mm LED lightbulb has been soldered onto the end of the cable.



HOW TO CONNECT

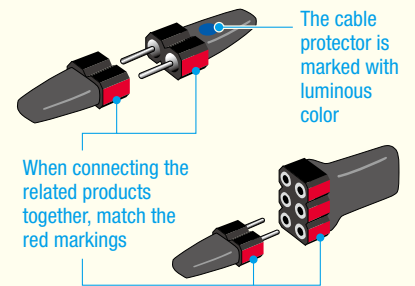

VAL-01W
1608 CHIP LED
WHITE



● Cable length : 50mm

VAL-01B
1608 CHIP LED
BLUE



● Cable length : 50mm

VAL-01G
1608 CHIP LED
GREEN

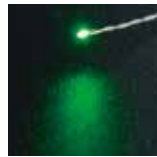

● Cable length : 50mm

VAL-02W
3mm SHELLY TYPE
LED WHITE



● Cable length : 50mm

VAL-02B
3mm SHELLY TYPE
LED BLUE



● Cable length : 50mm

VAL-02G
3mm SHELLY TYPE
LED GREEN



● Cable length : 50mm

HOW TO INSTALL A BATTERY

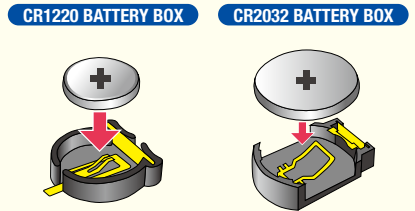

Place the plus side of the battery facing upwards, then put it inside the battery box

VAL-03 BATTERY BOX



VAL-03 battery box series is required if you are installing the LED modules. CR1220 battery box is recommend if you are prioritizing the space, and CR2032 is recommended if you are looking for more lighting power. Choose the right battery box for your needs.

※This product does not come with battery



Extension Cable

VAL-04 EXTENSION CABLE

VAL-04 is a line-up of extension cables. Use this extension cable with the LED lightbulb and battery box.

VAL-03A
CR1220 BATTERY BOX



● The length between the battery box, switch and socket : 50mm

VAL-03B
CR2032 BATTERY BOX



● The length between the battery box, switch and socket : 50mm

VAL-04A
EXTENSION CABLE



● Cable length : 200mm

VAL-04B
3BRANCH CABLE



● Cable length : 200mm

HOW TO TAKE OUT A BATTERY

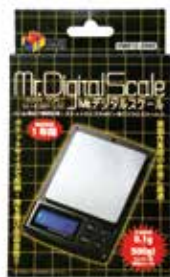
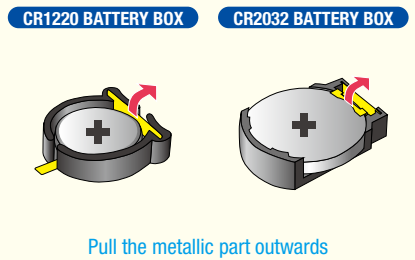

VM012 Mr.DIGITAL SCALE
● AAA DRY CELL BATTERIES×2 (available separately)



VM021 Mr.Hi-COATING II



SC101 SECTIONAL ACRYLIC DISPLAY CASE
FOR 1 : 700 SCALE
LARGE SIZE
WARSHIP MODEL KIT

- External dimensions 430mm×120mm×108mm
- Inside dimension 424mm×114mm×100mm



VM004 Mr.MOULDING BLOCK 1

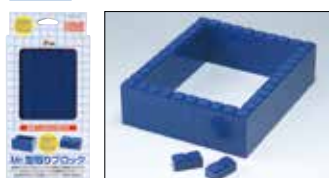

VM005 Mr.MOULDING BLOCK 2 (DOUBLE SIZE)

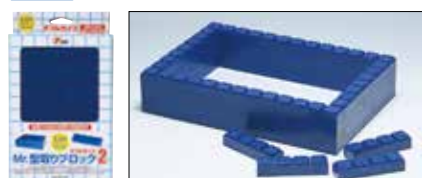

VM007 Mr.BLOCK PLATE FOR VM004 and VM005

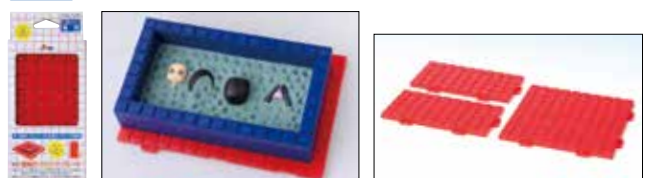

VM006 Mr.CLAY
(STONE CLAY)



VM009 Mr.CLAY 2
(OIL CLAY)



VM017 Mr.SCULPT CLAY
(BEIGE COLOR)



VM020 Mr.SCULPT CLAY
(GRAY COLOR)



VM022 Mr. CLAY
HARD TYPE



VM-015A Mr.CLAY FOR THE SCENE
(SAND)



VM-015B Mr.CLAY FOR THE SCENE
(MUD)



VM-015C Mr.CLAY FOR THE SCENE
(WHITE EARTH)



VM-015D Mr.CLAY FOR THE SCENE
(RED EARTH)



VM018 Mr.CLAY ROLLER



VM019
Mr.MODELING
PLASTER
FOR THE SCENE



Mr.PRO-SPRAY

PS182 PRO-SPRAY BASIC

0.2mm-0.4mm nozzle



An airbrush for beginners, which is reasonably priced and easy to handle. The main body of the airbrush has been made easier to grip. This is an improved version of the PRO-SPRAY series. Deluxe version of PRO-SPRAY BASIC is containing a stand and spiral hose, too.

PS183 PRO-SPRAY DELUXE

0.2mm-0.4mm nozzle



PS701
REPLACEMENT
GLASS BOTTLE
FOR
PRO-SPRAY



PS166 Mr.PRO-SPRAY Mk-6

0.2mm-0.4mm nozzle



PS240
Mr.AIR
VALVE



AIR

PA148
Mr.AIR
SUPER
190
NET:190ml



PA200
Mr.AIR
SUPER
420



Mr.LINEAR COMPRESSOR

PS305
Mr.LINEAR COMPRESSOR L5
/ PS289 AIRBRUSH

A full set of Mr. LINEAR COMPRESSOR L5 with airbrush PS-289 Mr. PROCON BOY WA PLATINUM Ver.2.



PS309
Mr.LINEAR COMPRESSOR L7
/ PS289 AIRBRUSH

A full set of Mr. LINEAR COMPRESSOR L7 with airbrush PS-289 Mr. PROCON BOY WA PLATINUM Ver.2.



Mr.LINEAR COMPRESSOR L5 / L7

PS251

PS251 Mr.LINEAR COMPRESSOR L5

- STANDARD PRESSURE 0.1Mpa
- MAXIMUM PRESSURE 0.12Mpa
- STANDARD VOLTAGE AC100V
- AIR ASPIRATED 5.27Lit/min
- STANDARD FREQUENCY 50/60Hz
- OPERATION CONTINUOUS
- SIZE 160 (L)×120 (W)×160 (H)
- WEIGHT 2.4kg

PS254



An epoch-making compressor with linear-driven free piston. Low noise makes this compressor ideal even at night and can run continuously 24 hours.

PS254 Mr.LINEAR COMPRESSOR L7

- STANDARD PRESSURE 0.1Mps
- MAXIMUM PRESSURE 0.15Mpa
- STANDARD VOLTAGE AC100V
- AIR ASPIRATED 7.0Lit/min
- STANDARD FREQUENCY 50/60Hz
- OPERATION CONTINUOUS
- SIZE 170 (L)×142 (W)×185 (H)
- WEIGHT 2.9kg

PS306 Mr.LINEAR COMPRESSOR L5 / PS290 AIRBRUSH

A full set of Mr. LINEAR COMPRESSOR L5 with airbrush PS-290, Mr. PROCON BOY LWA TRIGGER TYPE.



PS321 Mr.LINEAR COMPRESSOR L5 / PS274 AIRBRUSH



A full set of Mr.LINEAR COMPRESSOR L5 with airbrush PS264 Mr. PROCON BOY WA 0.3mm for those who want to enjoy airbrush painting.

PS310 Mr.LINEAR COMPRESSOR L5 / REGULATOR



A good set for those who have never used a compressor. This popular set of L5 includes a Mr.AIR REGULATOR and a Mr.AIR HOSE / PS STRAIGHT

PS313 Mr.LINEAR COMPRESSOR L5 / REGULATOR IV



A set of Mr.LINEAR COMPRESSOR L5 and Mr.AIR REGULATOR IV. The attached mounting base offers compact installation of the regulator and stand.

PS307 Mr.LINEAR COMPRESSOR L7 / REGULATOR



A set of Mr. LINEAR COMPRESSOR L7, Mr. AIR REGULATOR and Mr. STAND & TRAY SET II.

PS319 Mr.LINEAR COMPRESSOR L7 / PS270 & 289 AIRBRUSH

A full set of Mr. LINEAR COMPRESSOR L7 with airbrush PS270 & PS289.



PS-351KP Mr.LINEAR COMPRESSOR L3 BLACK



- STANDARD PRESSURE 0.05Mpa
- MAXIMUM PRESSURE 0.085Mpa
- AIR ASPIRATED 3.0Lit/min
- OPERATION 30min
- STANDARD VOLTAGE AC100V
- STANDARD FREQUENCY 50/60Hz
- SIZE 108 (L) × 70 (W) × 115 (H)
- WEIGHT 0.9kg

PS371 Mr.LINEAR COMPRESSOR CUTE



- STANDARD PRESSURE 0.03Mpa
- AIR ASPIRATED 3.0Lit/min
- OPERATION 60min
- STANDARD VOLTAGE AC100V
- STANDARD FREQUENCY 50/60Hz
- SIZE 140 (L) × 50 (W) × 83 (H)
- WEIGHT 290g

PS320 Mr.LINEAR COMPRESSOR L7 / PS289 & 290 AIRBRUSH

A full set of Mr. LINEAR COMPRESSOR L7 with airbrush PS289 & PS290.



PS-404B Mr.LINEAR COMPRESSOR L3 BLACK / PROCON BOY SQ LIGHT ALUMINIUM SKY BLUE

A full set of Mr.LINEAR COMPRESSOR L3 BLACK with airbrush PROCON BOY SQ LIGHT ALUMINIUM and Mr.AIR REGULATOR MkI.



PS-404R Mr.LINEAR COMPRESSOR L3 BLACK / PROCON BOY SQ LIGHT ALUMINIUM WINE-RED

A full set of Mr.LINEAR COMPRESSOR L3 BLACK with airbrush PROCON BOY SQ LIGHT ALUMINIUM and Mr.AIR REGULATOR MKI.



AIRBRUSH

PS770 Mr.AIR BRUSH CUSTOM 0.18 DOUBLE ACTION



Mr. AIR BRUSH CUSTOM 018 DOUBLE ACTION

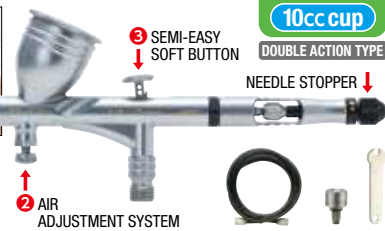

018 nozzle
10cc cup
DOUBLE ACTION TYPE

PS290 Mr.PROCON BOY LWA TRIGGER TYPE DOUBLE ACTION TYPE

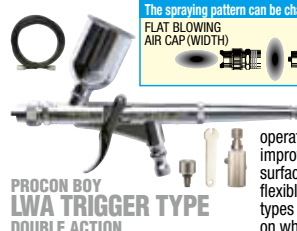

PROCON BOY LWA TRIGGER TYPE DOUBLE ACTION

The spraying pattern can be changed with two kinds of air caps. **FLAT BLOWING AIR CAP (WIDTH)** **CIRCLE BLOWING AIR CAP (USUALLY)**

A trigger type airbrush great for use on big surfaces. The hand operated trigger operation keeps fingers from getting fatigued, greatly improving the results of painting done on broad surfaces and for long periods of time. For even more flexible airbrushing, you can switch between two types of nozzle caps with different tip size depending on whether you want a normal or wide spray pattern.

05 nozzle
15cc cup
DOUBLE ACTION TYPE

PS270 Mr.PROCON BOY FWA PLATINUM 0.2 DOUBLE ACTION TYPE

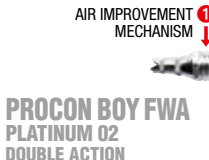

PROCON BOY FWA PLATINUM 02 DOUBLE ACTION



02 nozzle
10cc cup
DOUBLE ACTION TYPE

PS289 Mr.PROCON BOY WA PLATINUM 0.3 Ver.2 DOUBLE ACTION TYPE



PROCON BOY WA PLATINUM 03 Ver.2 DOUBLE ACTION

03 nozzle
10cc cup
DOUBLE ACTION TYPE

PS275 Mr.PROCON BOY WA TRIGGER DOUBLE ACTION TYPE

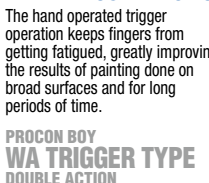

PROCON BOY WA TRIGGER TYPE DOUBLE ACTION



03 nozzle
7cc cup
DOUBLE ACTION TYPE

PS274 Mr.PROCON BOY WA DOUBLE ACTION TYPE



PROCON BOY WA DOUBLE ACTION

03 nozzle
10cc cup
DOUBLE ACTION TYPE

- ① AIR IMPROVEMENT MECHANISM It regulates the air flow so that stable operation is enabled even at low air pressure.
- ② AIR ADJUSTMENT SYSTEM The spray can be easily adjusted for metallic colors, quick drying paint, and other paint characteristics by simply controlling only airflow - no pressure adjustment is needed.
- ③ SEMI-EASY SOFT BUTTON Push down the button to adjust the fineness of the needle without paint squirting out when pulling the button. This enables smooth spraying whenever you pull the button.

PS267 Mr.PROCON BOY FWA DOUBLE ACTION TYPE



02 nozzle
10cc cup
DOUBLE ACTION TYPE

PROCON BOY FWA
DOUBLE ACTION

An ultrahigh-precision airbrush featuring a 0.2 mm nozzle diameter. This airbrush delivers great performance for ink-spot dazzle and fine-gradation painting. This is the first small-diameter model with 10-cc cup. This airbrush has a 1/8 (S) mouth with joint for PS (fine)

PS265 Mr.PROCON BOY SAE SINGLE ACTION TYPE



03 nozzle
7cc cup
SINGLE ACTION TYPE

PROCON BOY SAE
SINGLE ACTION

An airbrush with dial for easy spray adjustment by one thumb. This airbrush has a 1/8 (S) mouth with joint for PS (fine).

PS266 Mr.PROCON BOY LWA DOUBLE ACTION TYPE



05 nozzle
15cc cup
DOUBLE ACTION TYPE

PROCON BOY LWA
DOUBLE ACTION

The perfect airbrush for spraying a metal color or surface layer over a large area. This airbrush provides stable spraying even under low pressure. The 15-cc large cup of the direct-mount type makes it easy to wash. This airbrush has a 1/8 (S) mouth with joint for PS (fine)

PS268 Mr.PROCON BOY SQ SINGLE ACTION TYPE



04 nozzle
7cc cup
SINGLE ACTION TYPE

PROCON BOY SQ
SINGLE ACTION

This airbrush has all the standard requirements for an airbrush for beginners at an amazingly low price. Paint spray thickness is easily adjusted with the dial on the back of the unit. This airbrush has a 1/8(S) mouth with joint for PS(fine).

PS-268AB PROCON BOY SQ LIGHT ALUMINIUM SKY BLUE



PROCON BOY SQ LIGHT
SINGLE ACTION

PS-268AR PROCON BOY SQ LIGHT ALUMINIUM WINE-RED



04 nozzle
7cc cup
SINGLE ACTION TYPE

The weight has been significantly reduced by changing the material of the main body and paint cup from brass to aluminum (former type (PS268) 139g →73g). The main body is alumite processed, and the surface is coated in a bright beautiful color tone.

PS253 Mr.AIR REGULATOR / STAND



An essential item for airbrush painting equipped with decompression, draining, and branching functions.

PS259 Mr.AIR REGULATOR III



An installation-type regulator mounted on Mr.STAND. This regulator can not only be used for L5, L7 and L10, but also for other low-pressure compressors.

PS234 Mr.AIR REGULATOR WITH STAND FOR L5 & L7



PS282 DRAIN & DUST CATCHER



Even when using a regulator, water droplets can still collect on the inside of hoses during the humid rainy season. Connect this to your airbrush as an additional second defense against water droplets.



PS382 DRAIN & DUST CATCHER LIGHT

Comparison of weight from the former type : PS282 40.5g ▶ PS382 24.0g



PS288 DRAIN & DUST CATCHER II



Attached to your airbrush this combination of hand-grip and airfilter gets you better results by enabling you to regulate air flow by hand.



PS388 DRAIN & DUST CATCHER II LIGHT

These are Light type of PS282 and PS288, aluminum is used for the main body, so the stress on the wrist is reduced and work efficiency is improved.

Comparison of weight from the former type : PS288 51.3g ▶ PS388 30.0g



PS-290B 150cc CUP for PS290 and PS275



PS991 AIRBRUSH MAINTENANCE SET



PS283 Mr.ONE TOUCH JOINT 1/8 (S)



PS281 ONE TOUCH PLUG - 1/8 (S) for Mr.ONE TOUCH JOINT

PS241 Mr. HOSE JOINTS 3 PCS



JOINT 1 JOINT 2 JOINT 3
 □ 1/8(S) □ 1/8(S) PS □ 1/8(S) □ PS □ 1/8(S) □ PS □

PS244 Mr.AIR HOSE PS STRAIGHT 1.5M



PS245 Mr.AIR HOSE PS SPIRAL 1.5M



PS246 Mr.AIR HOSE 1/8 (S) STRAIGHT 2M



PS247 Mr.AIR HOSE 1/8 (S) SPIRAL 1M



PS-290G ADDITIONAL GRIP for PS290



PS256 Mr.STAND



PS229 Mr.STAND & TRAY SET I

● TRAY SIZE : 165mm×93mm



PS233 Mr.AIR REGULATOR STAND FOR L5 & L7



This hand grip is suitable for PS290 Airbrush. It has an excellent grip, so it would make it easier to hold and use the airbrush. There is no need to use any tool to place the hand grip onto the airbrush. Other additional parts, such as hose and joints, can be used together.

PS230**Mr.STAND & TRAY SET II**

● TRAY SIZE :
196mm×136mm

**PS257 Mr.CLEANER BOTTLE****SF285, B506 Mr.SURFACER 500**

This coating is useful for filling in bumps and dents in plastic models, scratches and for removing bubbles and finishing bases. It is suitable for large scale repairs and can be used as soluble putty.

SF284, B505, B519 Mr.SURFACER 1000

Mr.SURFACER 1000 contains finer granules than Mr.SURFACER 500. They are both used in much the same way but, due to the finer granules, after sanding with waterproof sand-paper a perfectly corrected surface is possible. Available in bottle and as spray.

B515 Mr.SURFACER 1200

Mr.SURFACER 1200 contains finer granules than Mr.SURFACER 1000. They are both used in much the same way.

B511 Mr.WHITE SURFACER 1000

Since it is white, Mr.WHITE SURFACER is used to modify plastic model parts that are black or dark in color. If this is used on the entire model, only a thin over-coat of paint in the desired color is necessary.

SF283, B518 Mr.BASE WHITE 1000

Mr. BASE WHITE is useful for making a black, red or other dark-colored surface white. This newly developed product uses special pigments to completely hide the base color and aids application of detailed finishing and top coats. Because it also works as a surfacer, it can be used to hide small imperfections.

B524, SF287 Mr.PRIMER SURFACER

This is a surfacer with primer. The material used in Surfacers 1000 has been improved for this product. Surface attachment has been enhanced not only for plastic models but also for metal in etched parts and resin. Color is gray.

B525 Mr.OXIDE RED SURFACER

This surfacer has reproduced the rust-proofing color used as the base color on tanks. Base coat painting on tanks can be done in one go, so that you can start painting the exterior within a shorter time. This product has the same grade as the widely used Surfacers 1000.

Differences between B518 Mr.BASE WHITE 1000 SPRAY and B511 Mr.WHITE SURFACER 1000 SPRAY

Both items are used in almost the same way, but the amount of pigments is different. B518 contains less granules but more white pigments than B511, so it is great for filling in bumps and dents and you get a whiter surface than with B511. B511 on the other hand contains more granules, so it is easier to fill in scratches with it. Its color is a bit greyish.

SF288, B526 Mr.FINISHING SURFACER 1500 BLACK

This is a black version of the Finishing Surfacers. This black base allows the omission of the painting of a black coat before applying a metallic color and reduces the thickness of painting.

* This is not suitable for finishing before painting on SM08 Plate Silver Next. It is necessary to apply a gloss black paint separately or polish the surface.

SF289, B527 Mr.FINISHING SURFACER 1500 GRAY

This surfacer can be applied to give a final finish to the surface more smoothly. It has the characteristic of being fine grained and it is not prone to clogging up details in the mold. Most suitable not only for making a base before painting but also for surface finishing of an original mold before casting.

SF290, B528 Mr. MAHOGANY SURFACER 1000

Surfacers in mahogany color (dark brown). This surfacer can be applied to smooth the surface and it can also be applied as a dark brown base paint shading color, this gives depth to the end result after the basic color is applied on top.

T302, 303 ACRYSION THINNER

Thinner for new water based color "ACRYSION". Dilution ratio is 3 paint: 1 thinner when you paint by airbrush.

T106, 108 Mr.COLOR LEVELING THINNER

Mr. LEVELING THINNER is excellent for spray (airbrush) applicators. Mixing Mr. LEVELING THINNER into Mr. COLOR at a ratio of 1:1 or 1:2 improves coat leveling and increases shine. When drying is slow because of insufficient air current during winter months, it is best to mix Mr. COLOR THINNER into Mr. LEVELING THINNER. The mixture will be dry to the touch after a period of about 10 minutes.

T117 Mr.RAPID THINNER

Drying speed when an air brush is used is faster than with the regular thinner, and when metallic paint is used in particular, metallic particles are aligned evenly to produce a neat glossy surface. This is also suitable for dilution of surfacer and mat paint, and also for camouflage painting and gradation painting. * Because of the fast drying speed, we do not recommend this for glossy paint types other than metallic painting. Please use Mr. Leveling Thinner for glossy painting.

SM201 - 206 and SM08 Mr.COLOR SUPER METALLIC

The SUPER METALLIC Series is a metallic paint, which uses high class fine metallic particles.

The base material used is the same as that for Mr.Color.
• Please use T106, T108 Mr.Color Leveling Thinner or T117 Mr.Color Rapid Thinner for paint dilution and airbrush painting.
• For airbrush painting, dilute paint with thinner to a ratio of 1 paint : 1~2 thinner (excluding SM08).

• For further glazing, coat the surface using B513 Super Clear Gloss, etc (excluding SM206 and SM08).

***Notes**

- For SM206 and SM08, be sure to apply Mr.Color black (gloss) as a base coat color before painting in order to give a metallic touch.
- In case of SM206 and SM08, clear paint can not be applied over the painted surface (it dulls the color).
- Metallic particles tend to set easily, so stir well when thinning and even during painting.
- Needle airbrushes tend to clog easily with metallic particles, so do not attempt an extremely fine spray. Use an airbrush with a bore diameter of over 0.3mm.

CR1. CR2. CR3 PRIMARY COLOR PIGMENTS FOR Mr.COLOR

Primary color pigments for Mr.Color are coating additives for which concentration of the three primary colors cyan, magenta, and yellow, that are raw materials of Mr.Color, is adjusted to allow color mixing with Mr.Color while keeping high purity. Since Primary color pigments for Mr.Color do not include any pigments that conceal foundation coat (such as white and black), these cannot be used as single units in a similar way to other paints, but these are useful for fine adjustment of tint of existing colors without making muddy, natural gradation coating with vivid color tone by making use of high color transparency, and metallic color toning.

Also by mixing it into GX100 Super ClearII, original clear colors can be made for coating clear parts.

***As used above**

With Primary color pigments for Mr.Color, the intensity of coloring is in the order of cyan, magenta, and yellow (lowest).

When mixing colors, be sure to add a higher intensity color little by little to a lower intensity color.

As the rate of addition of Primary color pigments for Mr.Color becomes higher, the ground masking capacity of color becomes lower.

For beautiful coloring, conduct undercoating with a color made by mixing C1 WHITE of the same quantity or twice to mixed paint.

For beautiful painting surface finish, conduct wet-on-wet coating of a thinly diluted color little by little by suppressing the discharge of airbrush.

GT65 Mr.LINE CHISEL

The line chisel is a precision cutting tool dedicated for chiseling lines.

Since the cutting edge is convex, this can be used to chisel easily to make thin grooves with uniform width.

Since the blade is detachable, it can be replaced, according to the application, with a different sized one that is sold separately.





Mr. COLOR

WATER BASED COLOR
ACRYSION

HOBBY COLOR



Mr. COLOR GX

Mr. Clear COLOR GX
Mr. クリアカラーGX

Mr. Metallic COLOR GX
Mr.メタリックカラーGX

Mr. COLOR
SUPER METALLIC

Mr. COLOR SPRAY



Mr. WEATHERING COLOR
FOR REALISTIC MODELING
Mr.ウェザリングカラー

Mr. COLOR THINNER

January, 2019 Issue



GSI Creos Corporation

HOBBY DEPT.

3-1, Kudanminami 2-chome, Chiyoda-ku, Tokyo 102-0074, JAPAN

